

201/203 Schwinn® Recumbent Exercise Bike

*Parts List
Full Size Hardware Chart
Product Illustration
Assembly Instructions*

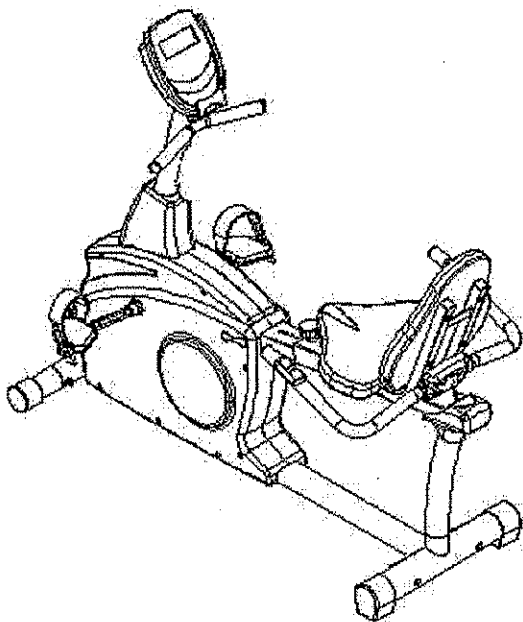

*201 Recumbent Exercise
Bike*

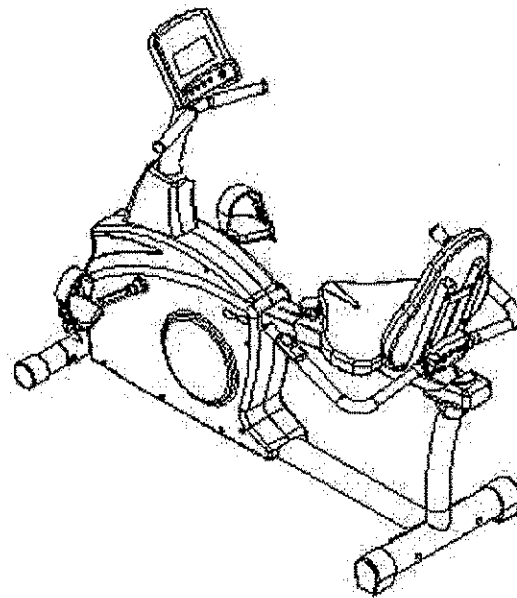

*203 Recumbent Exercise
Bike*

IMPORTANT PRECAUTIONS

WARNING: To reduce the risk of serious injury, please read the following precautions before using the Schwinn 201/203.

1. It is the responsibility of the owner to ensure that all users of this equipment are adequately informed of all precautions.
2. Read all instructions in this manual and in the accompanying literature and follow them carefully before using the equipment.
3. If you feel pain or dizziness at any time while exercising, stop immediately and consult your physician.
4. Use this equipment only on a solid level surface. Cover the floor or carpet beneath this equipment for protection.
5. Inspect and tighten all parts often. Replace any worn parts immediately.
6. Keep small children and pets away from this equipment at all times.
7. Always wear athletic shoes for foot protection. Do not wear loose or dangling clothing while using exercise bicycle.
8. Care should be taken when mounting or dismounting the exercise bicycle.
9. Read all warnings posted on the exercise bicycle.
10. User weight limit on the Schwinn 201/203 is 275 lbs.

This **Schwinn 201/203** is intended for home use only. Do not use this equipment in any non-residential environment.

WARNING: Before beginning this or any exercise program, consult your physician. This is especially important for persons over the age of 35 or persons with pre-existing health problems. Read all instructions before using. We assume no responsibility for personal injury or property damage sustained by or through the use of this product.

201/203 Schwinn Recumbent Bike Parts List, Hardware Chart, and Assembly Instructions

Assembly of the 201/203 Recumbent Bike is divided into 5 easy stages; each comprised of only a few setup steps. Before proceeding with the assembly, please read over the easy to follow instructions to familiarize yourself with the process.







- A flat area of 5' x 7' is suggested to assemble and properly use the 201/203 exercise bike.
- You will need the following tools to complete the assembly:
5mm Allen wrench (supplied)
Open wrench 13mm, 14mm, 15mm (supplied)
Phillips screwdriver (supplied)

Also, to ensure quick and easy set up of the 201/203 Recumbent Bike, please verify the size and quantity of each of the enclosed assembly hardware. Included is a handy full size hardware chart and parts list of each of the required assembly hardware. Simply match up the corresponding hardware to each full size drawing.

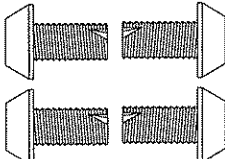
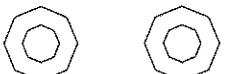
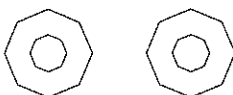
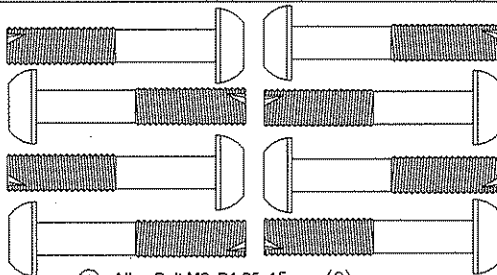
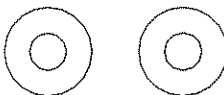
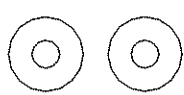
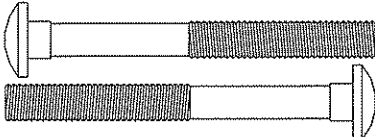
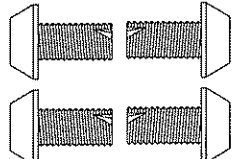
Parts List

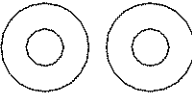
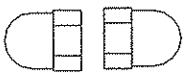
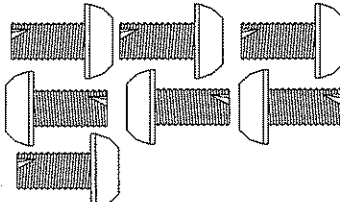
Check	Quantity	Description	Reference #
—	8	Allen Bolt M8 x P1.25 x 45mm	1
—	15	Flat Washer	2
—	1	Seat Pin Adjustment Knob	3
—	1	Seat	4
—	1	Seat Back	5
—	1	Handlebar Assembly	6
—	8	Flat Washer $\phi 8 * \phi 16 * 2T$	7
—	1	Seat Frame Assembly	8
—	1	Seat Rail	9
—	1	Rear Stabilizer Tube	10
—	1	End Cap (for #9)	11
—	1	Buffer	12
—	1	Buffer Plate	13
—	2	Flat Washer for 12/13	14
—	2	Screw for 12/13	15
—	2	Carriage Bolt M8 x P1.25 x 75mm	16
—	1	Front Stabilizer Tube (w/wheels)	17
—	1pr	Pedal Strap (Left & Right)	18
—	8	Curved Washer	19
—	4	Acorn Nut	20
—	1pr	Pedals (Left & Right)	21
—	19	Allen Bolt M8 x P1.25 x 16mm	22
—	2	Bolt Cover	23
—	2	Carriage Bolt M8 x P1.25 x 90mm	24
—	1	Computer Cable (Lower)	25
—	1	HR Cable (Lower)	26
—	1	Console Mast Cover	27
—	1	Computer Cable (Upper)	28
—	1	HR Cable (Upper)	29
—	1	Console Mast	30
—	1	Main Unit	31
—	1	Lower Base Frame	32
—	4	Computer Mounting Screws	33
—	1	Computer	34
—	1	HR Cable (Seat Rail)	47
—	2	Water Bottle Cage Mounting Screws	56
—	1	Water Bottle Cage	57
—	1	AC Adapter	50

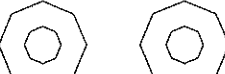
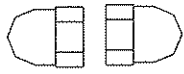
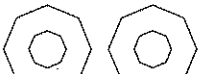
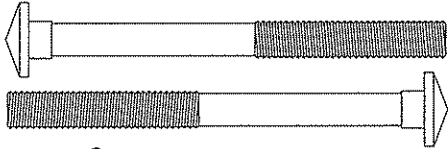
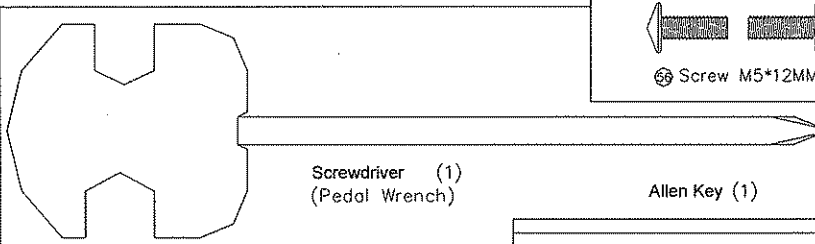
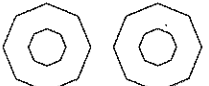
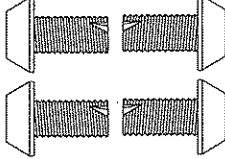
Hardware Chart

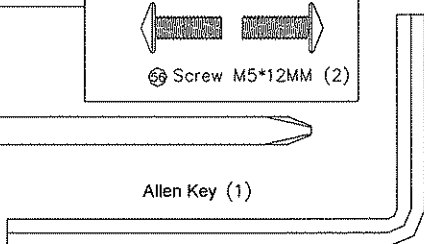
<p>Stage#1</p>  <p>⑫ Allen Bolt M8xP1.25x16mm (4)</p>  <p>⑦ Flat Washer for φ 8*φ 16*2T (4)</p>  <p>② Flat Washer φ 8*φ 19*2T (8)</p>	 <p>① Allen Bolt M8xP1.25x45mm (8)</p>  <p>② Flat Washer φ 8*φ 19*2T (4)</p>  <p>⑭ Flat Washer φ 6*φ 16*1t (2)</p>  <p>⑮ Carriage Bolt M8xP1.25x75mm (2)</p>	<p>Stage#2</p>  <p>⑫ Allen Bolt M8xP1.25x16mm (4)</p>  <p>⑮ Screw M5*35MM (2)</p> <p>Stage#3</p>  <p>⑰ Curved Washer φ 8*φ 19*2t (2)</p>  <p>⑳ Acorn Nut M8 (2)</p>
<p>Stage#4</p>  <p>⑫ Allen Bolt M8xP1.25x16mm (7)</p>  <p>⑦ Flat Washer φ 8*φ 16*2T (4)</p>  <p>② Flat Washer φ 8*φ 19*2T (3)</p>  <p>⑳ Acorn Nut M8 (2)</p>  <p>⑰ Curved Washer φ 8*φ 19*2t (2)</p>	 <p>⑭ Carriage Bolt M8xP1.25x90mm (2)</p>  <p>Screwdriver (1) (Pedal Wrench)</p>	<p>Stage#5</p>  <p>⑰ Curved Washer φ 8*φ 19*2t (4)</p>  <p>⑫ Allen Bolt M8xP1.25x16mm (4)</p>  <p>⑮ Screw M5*12MM (2)</p>  <p>Allen Key (1)</p>

Note: Please verify you have all correct parts and quantities before assembling unit.

If you are missing items, are short quantities, or have damaged components, please contact Schwinn at 1.800.864.1270.

201/203 Assembly Drawing with Reference Numbers

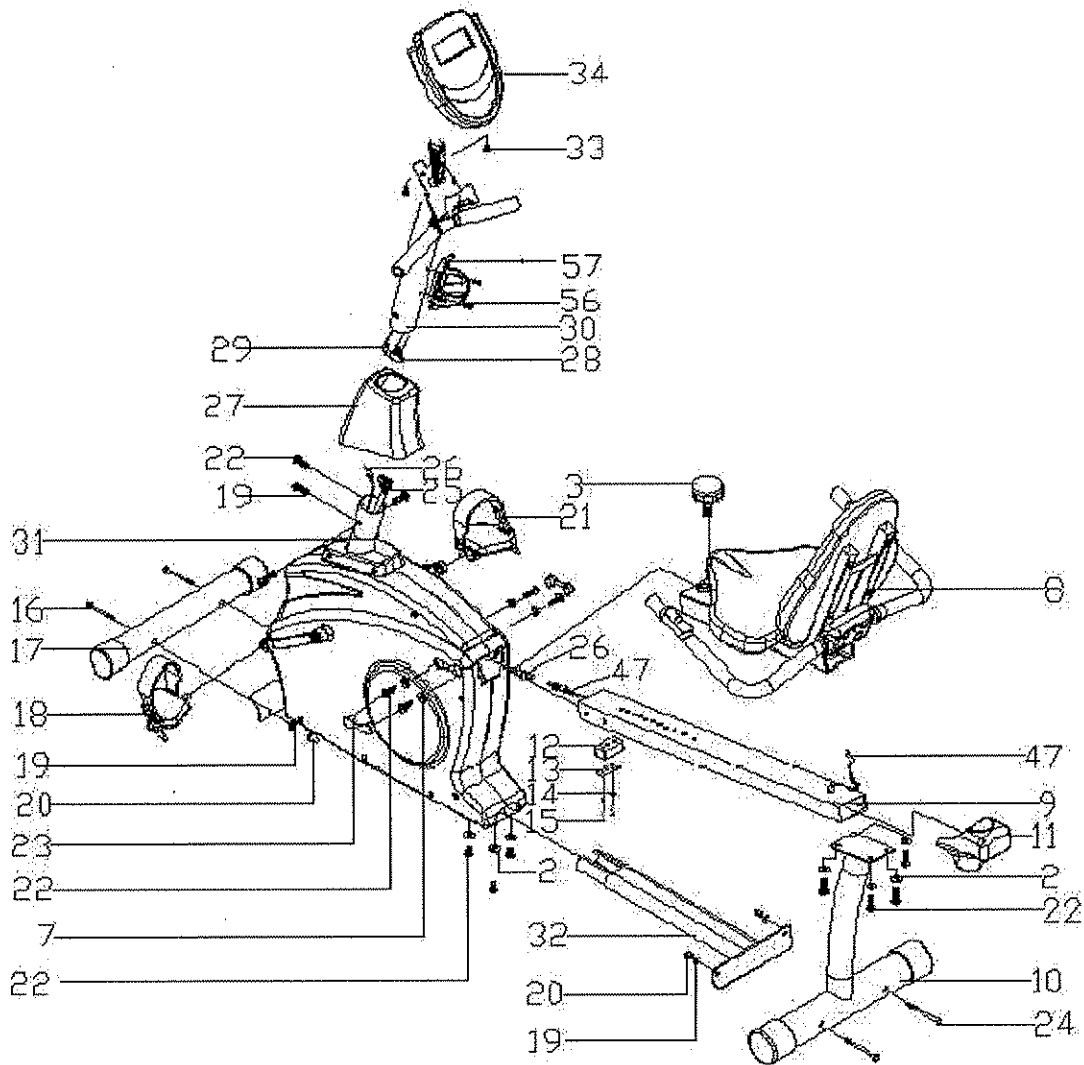

Replacement Parts List

Reference #	Description	Part #
3	Seat Pin Adjustment Knob	18079
4	Seat	18051(201) 18089(203)
5	Seat Back	18050(201) 18088(203)
6	Handlebar Assembly	18049(201) 18087(203)
7	Flat Washer	18088
9	Seat Rail	18080
10	Rear Stabilizer Tube	18076
11	Seat Rail End Cap	18081
12	Buffer	18053
13	Buffer Plate	18053
14	Flat Washer 12/13	18053
15	Screw for 12/13	18053
16	Carriage Bolt M8 x P1.25 x 75mm	18002
17	Front Stabilizer Tube (w/wheels)	18057
20	Acorn Nut	18004
21	Pedals (Left & Right)	98148 (201) 18048 (203)
22	Allen Bolt M8 x P1.25 x 16mm	18001
23	Bolt Cover	18084
24	Carriage Bolt M8 x P1.25 x 90mm	18089
25	Computer Cable (Lower)	18063
26	HR Cable (Lower)	18064
27	Console Mast Cover	18058
28	Computer Cable (Upper)	18085
29	HR Cable (Upper)	18086
30	Console Mast	18087
32	Lower Base Frame	18075
33	Computer Mounting Screws	18096
34	Computer	18033(201) 18047(203)
56	Water Bottle Cage Mounting Screw	18094
57	Water Bottle Cage	18005

Instructions

IMPORTANT!: To ensure ease of assembly please verify the size and quantity of all the required assembly hardware and parts with the enclosed parts list and full size hardware chart.

Each step of the assembly process has been broken down into 5 easy-to-follow stages. Please take just a few moments to read over these instructions to familiarize yourself with the process to make assembly quick and trouble-free.

Assembly Stage #1

Assemble Seat and Handle Bar

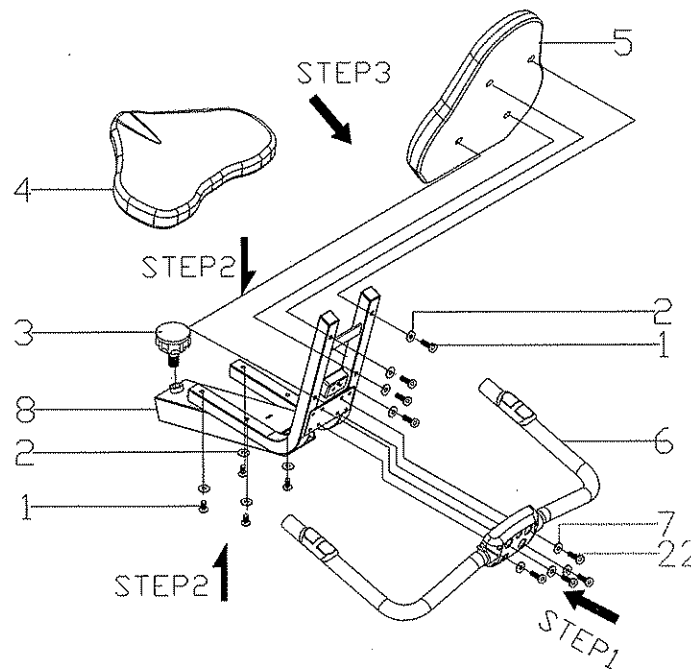

Assembly hardware required:

- (8) M8 Allen Bolts 45 mm long (item #1)
- (8) Flat Washers Ø8*Ø19*2T (item #2)
- (4) M8 Allen Bolts 16 mm long (item #22)
- (4) Flat Washer Ø8* Ø 16*2T(item #7)

Step 1: Attach HANDLEBAR ASSEMBLY (#6) to SEAT FRAME (#8) with the 4 ALLEN BOLTS (#22) and 4 FLAT WASHERS (#7). Tighten bolts with the provided Allen wrench.

Step 2: Attach SEAT (#4) to SEAT FRAME (#8) with 4 ALLEN BOLTS (#1) and 4 WASHERS (#2). Tighten Bolts.

Step 3: Attach SEAT BACK (#5) to SEAT FRAME (#8) with 4 ALLEN BOLTS (#1) and 4 WASHERS (#2). Tighten Bolts.

Note: Finished seat should look like picture below:

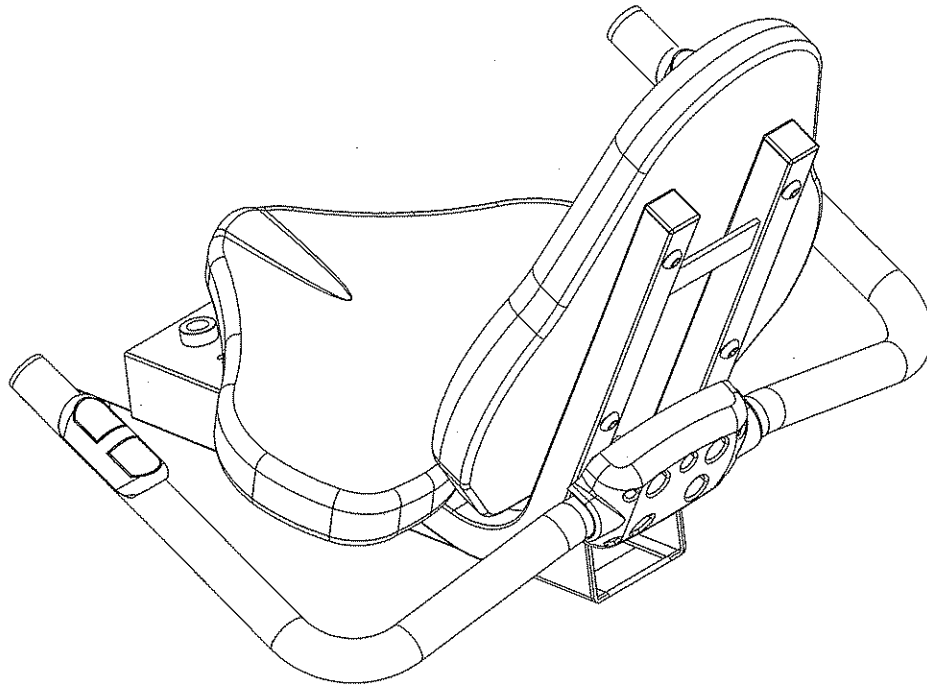

Assembly Stage #2

Attach Rear Stabilizer and Seat Rail to Seat Assembly

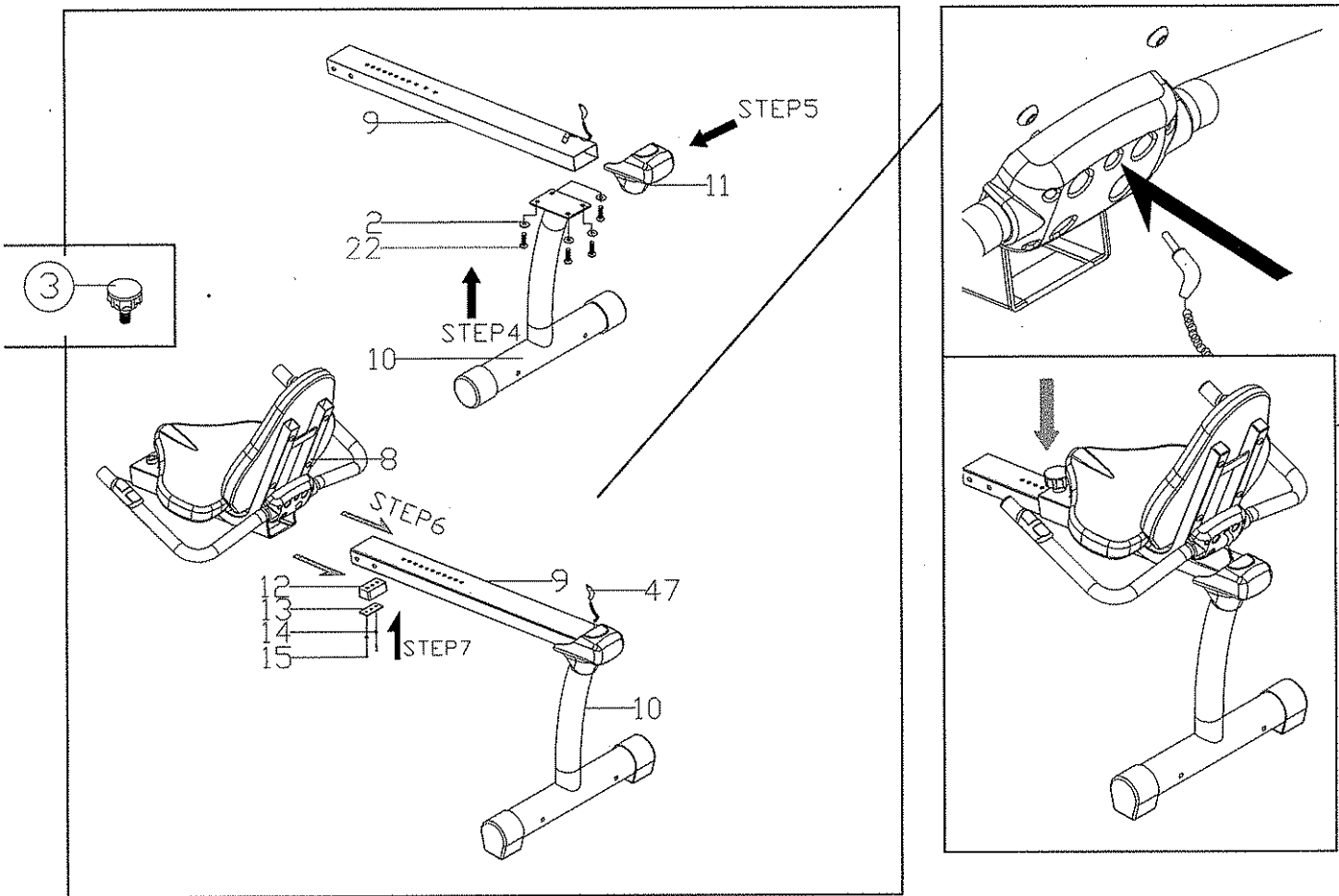

Assembly hardware required:

(4) M8 Allen Bolts 16mm (item #22)

(4) Flat Washers Ø8 * Ø19 * 2T(item#2)

Step 4: Attach SEAT RAIL (#9) to REAR STABILIZER TUBE (#10) with 4 FLAT WASHERS (#2) and 4 ALLEN BOLTS (#22). Tighten bolts.

Step 5: Place END CAP (#11) on the end of the SEAT RAIL (#9). Make sure the HR CABLE (#47) is strung through the exit slot on the SEAT RAIL before end cap is secured.

Step 6: Insert SEAT PIN ADJUSTMENT KNOB (#3) into SEAT FRAME (#8). Slide the seat assembly from stage 1 onto the SEAT RAIL (#9). Tighten seat assembly to the rail with the SEAT PIN ADJUSTMENT KNOB (#3). Insert HR CABLE (#47) into HR input on the back of the seat assembly.

Assembly Stage #3

Attach Front Stabilizer Tube and Pedals to Main Unit

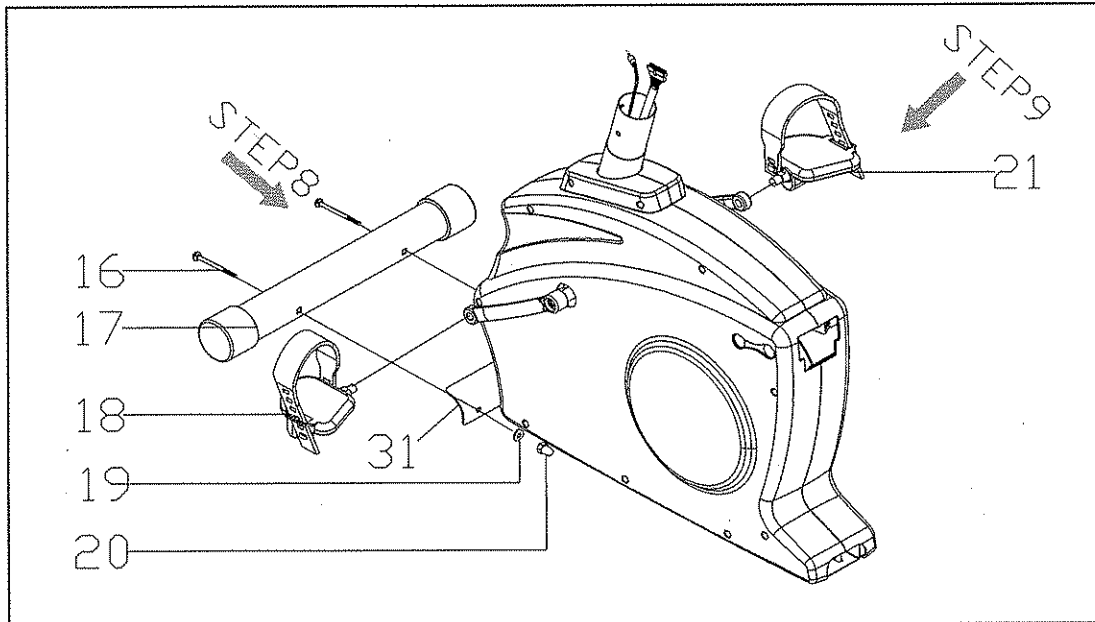

Assembly Hardware Required:

- (2) M8 Bolt 75mm long (item #16)
- (2) Curved Washers (item #19)
- (2) Acorn Nut (item #20)

Step 8: Attach FRONT STABILIZER TUBE (#17) to the MAIN UNIT (#31) with the M8 BOLT 75mm (#16), CURVED WASHER (#19), and ACORN NUT (#20). Tighten Bolts with provided wrench.

Step 9:

Attach RIGHT PEDAL (#21) to the right crank arm on the MAIN UNIT (#31).

Thread the pedal onto the crank arm and then tighten with pedal wrench.

Attach LEFT PEDAL (#21) to the left crank arm on the MAIN UNIT (#31). Thread the pedal onto the crank arm and then tighten with pedal wrench. **Note: There is a right pedal and a left pedal, marked by R and L. The threading on the left pedal is reversed from the right pedal. Counterclockwise rotation tightens while Clockwise rotation loosens on the left pedal. To avoid stripping of the threads be careful to use the proper pedal.**

Attach PEDAL STRAPS (#18) to each PEDAL (#21). Again, each strap is labeled with an R or an L corresponding to the right and left pedal straps.

Assembly Stage #4

Attach Seat Rail and Lower Base Frame to Main Unit

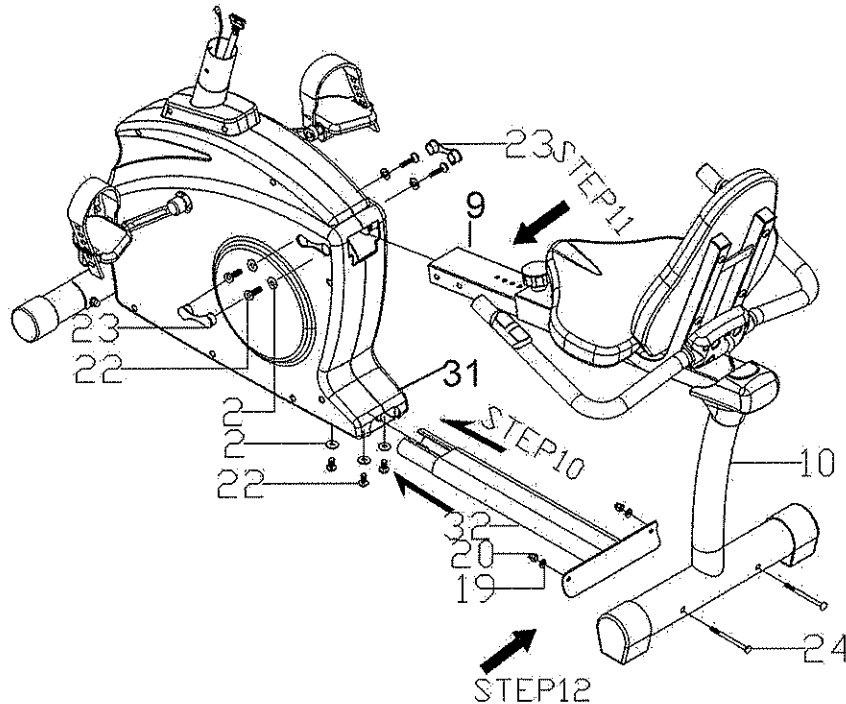

Assembly Hardware Required:

- (7) Allen Bolts 16 mm long (item #22)
- (3) Flat Washers (item #2)
- (2) Allen Bolts 90 mm long (item #24)
- (2) Curved Washers (item #19)
- (4) Flat Washer (item #7)

Step 10: Slide the LOWER BASE FRAME (#32) into the MAIN UNIT (#31), attach with 3, 16mm BOLTS (#22) and 3 FLAT WASHERS (#2). Do not completely tighten until after step 12.

- IMPORTANT -

Before proceeding to step 11 please complete the following steps. Failure to do so could lead to damage to the handgrip heart rate wires!

- 1) Remove END CAP (#11) from the end of the seat rail. The coiled wire seen above the seat rail needs to be re-routed out the back of the seat rail .
- 2) Pull the wire from the back of the seat rail until the male prong is flush with the front of the seat rail. Connect the cables from MAIN UNIT and Seat Rail. Tape can be used around the attachment of the two cable ends to ensure that they do not become disconnected.
- 3) Gently pull the excess cable from the back of the seat tube so that the cable running through the seat rail is taut. Be careful not to pull apart the cable connection you have just made. Slide the seat rail with seat assembly gently into the main unit, while pulling the cable tight from the back of the seat rail. Slide the seat rail slowly into the main unit. Using a flashlight check to make sure that the cable is not protruding from the bottom of the seat rail as it slides

into main unit. **CAUTION! If the wire is protruding from the bottom of the seat rail it may be severed or damaged when the seat rail is fully inserted into the main unit! This may result in a non-functioning handgrip heart rate.** Carefully slide the seat rail until the slots in the side of the rail line up with the holes in the main unit.

Step 11: Attach SEAT RAIL (#9) to MAIN UNIT (#31) with 4, 16 mm BOLTS (#22) and 4 FLAT WASHERS (#7). Again do not tighten until after step 12. Place BOLT COVERS (23) over BOLTS (#22) in MAIN UNIT (#31).

Step 12: Attach REAR STABILIZER TUBE (#10) to BASE FRAME (#32) with 2 90mm LONG BOLTS (#24), 2 CURVED WASHERS (#19), and 2 ACORN NUTS (#20). Tighten with provided wrench. Tighten Allen bolts from steps 10 and 11 with provided Allen wrench.

Step 12b: Feed the excess coiled wire from the back end of the seat rail through the hole on top of the seat rail until about 6 inches of coiled wire is on the outside of the seat rail. Attach the end of the wire to the back of the handlebar assembly. Feed the remaining excess wire into the seat rail and replace the end cap on the end of the seat rail. After completing assembly stage 5 verify that the handgrip heart rate works by hitting manual start and then placing your hand on the grip heart pad located on the handlebars. Verify that a heart rate registers on the computer panel after several seconds.

Assembly Stage #5

Attach Console Mast to Main Unit

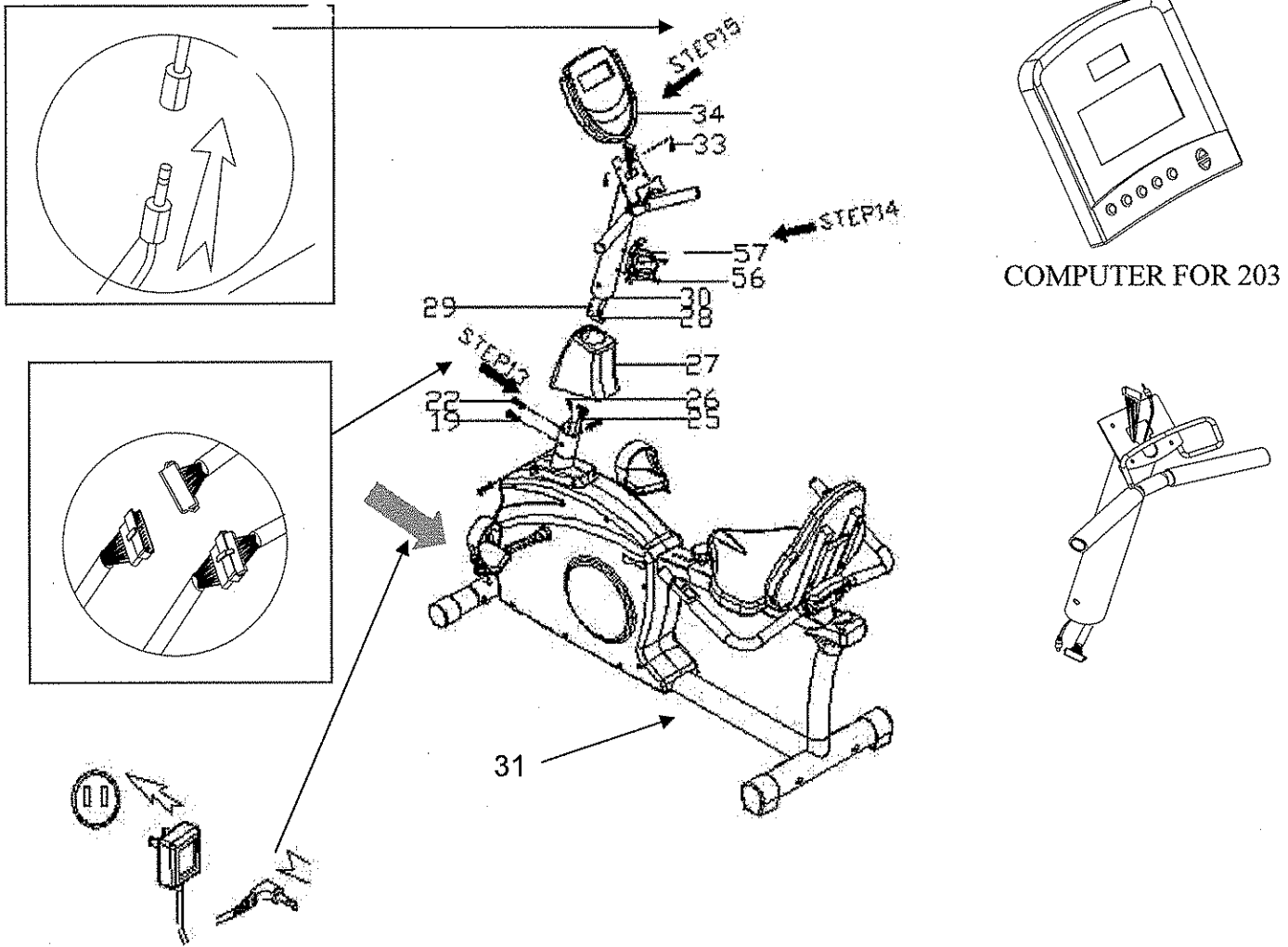

Assembly Hardware Required: (4) Allen Bolts 16 mm long (item #22)
(4) Curved Washers (item #19)
(4) Computer Screws (item #33)
(2) Water Bottle Cage Screws M5*12 mm (item #56)

Step 13: Run CONSOLE MAST (#30) through the CONSOLE MAST COVER (#27) and onto the MAIN UNIT (#31). Before fastening the CONSOLE MAST, attach both HR CABLES (#29 & #26) as well as the COMPUTER CABLE (#28 & #25). To easily complete this step it would be helpful to have someone hold the CONSOLE MAST (#30) and CONSOLE MAST COVER (#27) while connecting the cables. Fasten with 4 BOLTS (#22) and 4 CURVED WASHERS (#19). Tighten with provided Allen wrench.

Step 14: Attach WATER BOTTLE CAGE (#57) to CONSOLE MAST (#30) with SCREWS (#56). Tighten with Phillips head screwdriver.

Step 15: Attach UPPER COMPUTER CABLE (#28) and HR CABLE (#29) to under side of COMPUTER (#34). Place COMPUTER (#34) on top of CONSOLE MAST (#30), the reading rack should wrap around the bottom of the COMPUTER. Attach

COMPUTER to CONSOLE MAST with COMPUTER MOUNTING SCREWS (#33).
(In computer back) Tighten with Phillips head screwdriver.

Step 16: Plug power adapter into the wall and into the recumbent bike. The power input on the bike is located at the front end of the MAIN UNIT (#31) just above the FRONT STABILIZER TUBE (#17)

Seat Adjustment

For best results, the seat should be adjusted for your height.

1. Unlock "seat locking" mechanism.
2. Adjust seat location so that with feet on the pedals, you can comfortably reach pedal at full extension.

That's it!

You're finished and now you can begin to reach your fitness goals!

Please reference the Owner's Manual for information regarding computer operation, product maintenance, warranty information, and general fitness and exercise guidelines.

Schwinn Customer Service
1.800.864.1270

Troubleshooting the Schwinn 201, 203 Recumbent Exercise Bike

TIP: Use assembly diagram(s) as reference when troubleshooting unit.

PROBLEM: Computer will not start, function, or is blank...

- (SOLUTION):**
1. Ensure the batteries the unit is plugged into a 110v outlet.
 2. Check the wiring connections and connector orientation made to the computer.
 3. Confirm that wiring (cable assembly) has not been damaged
 4. If computer still fails to start please call 1.800.864.1270 for assistance.

PROBLEM: No Heart Rate on computer...

- (SOLUTION):**
1. Check the connections made at the computer and handlebars
 2. If heart rate still fails to work call 1.800.864.1270 for assistance.

PROBLEM: Bike will not sit level...

- (SOLUTION):**
1. Adjust the levelers on the rear stabilizer.

Note: If you need additional support information or assistance in troubleshooting, please contact us at: 1.800.864.1270