



**SCHWINN FITNESS**

## Schwinn® MPower™ Console + Power



### Owner's Manual



**English**

# Table of Contents

Specifications	2	Device Pairing	11
Important Safety Instructions	3	Configuration / Service Mode	13
Features	4	IC Class Setup	25
LCD Display Data	5	Troubleshooting	26
Wireless Bike Sensor Data	8	Maintenance	28
Operations	9	Contacts	31

## Specifications

### Console

Length	7.1" (18 cm)
Width	3" (7.7 cm)
Thickness	1.9" (4.8 cm)
Weight (console w/sensor)	2.0 lb (0.9 kg)
Shipping Weight	2.8 lb (1.3 kg)

### Power Sensor

Length	5.2" (13.3 cm)
Width	1.8" (4.5 cm)
Thickness	1.2" (3 cm)
Weight	0.17 lb (0.08 kg)
Shipping Weight	0.22 lb (0.1 kg)

### Speed Sensor

Length	3.3" (8.3 cm)
Width	2.5" (6.4 cm)
Thickness	1.5" (3.7 cm)

### Power Requirements

Console	(2) C Batteries (LR14)
Speed Sensor	(1) CR2032 Battery
Power Sensor	(1) AA Battery (LR6)



DO NOT dispose of this product as refuse. This product is to be recycled. For information on the proper method of disposal, contact a Nautilus Customer Service Representative. Contact information is available in the Contacts section in this manual. For additional information please visit:

[www.nautilus-international.net/recycle](http://www.nautilus-international.net/recycle)

**Patent Information** This product may be covered by US and Foreign Patents and Patents Pending.

© 2009 Nautilus, Inc., All rights reserved

™ and ® indicate a trademark or registered trademark. Nautilus, Inc. ([www.nautilus.com](http://www.nautilus.com)) trademarks include NAUTILUS®, BOWFLEX®, STAIRMASTER®, SCHWINN® and UNIVERSAL® and respective logos. Other trademarks are the property of their respective owners.

# Important Safety Instructions



Indicates a potentially hazardous situation which, if not avoided, could result in death or serious injury.

## Before using this equipment, obey the following warnings:



Read and understand the complete Owner's Manual. Keep Owner's Manual for future reference.

Read and understand all warnings on this machine. If at any time the Warning stickers become loose, unreadable or dislodged, contact Nautilus Customer Service for replacement stickers.

- Children must not be let on or near to this machine. Moving parts and other features of the machine can be dangerous to children
- Consult a physician before you start an exercise program. Stop exercising if you feel pain or tightness in your chest, become short of breath, or feel faint. Contact your doctor before you use the machine again. Use the values calculated or measured by the machine's computer for reference purposes only.
- If you have a pacemaker or other implanted electronic device, consult your doctor before using a wireless chest strap or other telemetric heart rate monitor.
- Do not use or put the machine into service until the machine has been fully assembled and inspected for correct performance in accordance with the Owner's Manual.
- Read and understand the complete Owner's Manual supplied with the machine before first use. Keep the Owner's and Assembly Manuals for future reference.

## FCC Compliance



Changes or modifications to this unit not expressly approved by the party responsible for compliance could void the user's authority to operate the equipment.

**Note:** This device complies with Part 15 of the FCC Rules. Operation is subject to the following two conditions: (1) this device may not cause harmful interference, and (2) this device must accept any interference received, including interference that may cause undesired operation. These limits are designed to provide reasonable protection against harmful interference in a residential installation. This equipment generates uses and can radiate radio frequency energy and, if not installed and used in accordance with the instructions, may cause harmful interference to radio communications. However, there is no guarantee that interference will not occur in a particular installation. If this equipment does cause harmful interference to radio or television reception, which can be determined by turning the equipment off and on, the user is encouraged to try to correct the interference by one or more of the following measures:

- Reorient or relocate the receiving antenna.
- Increase the separation between the equipment and receiver.
- Consult the dealer or an experienced radio/TV technician for help.

# Features

Front

Back

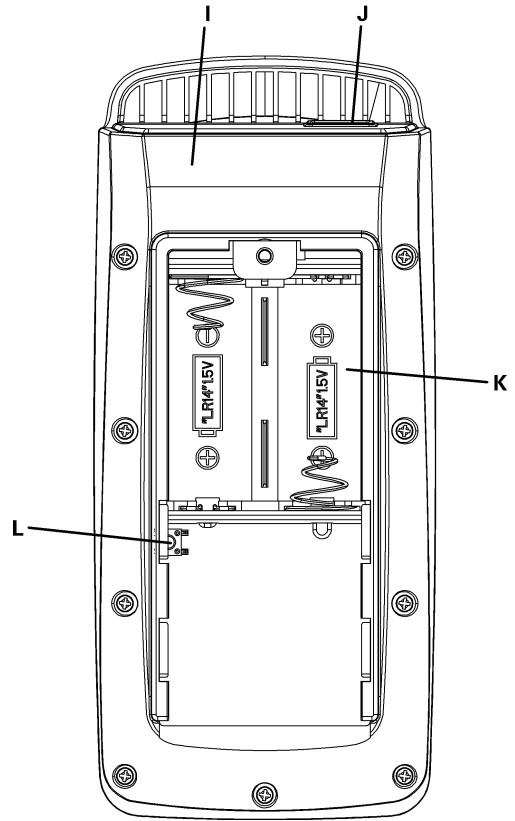
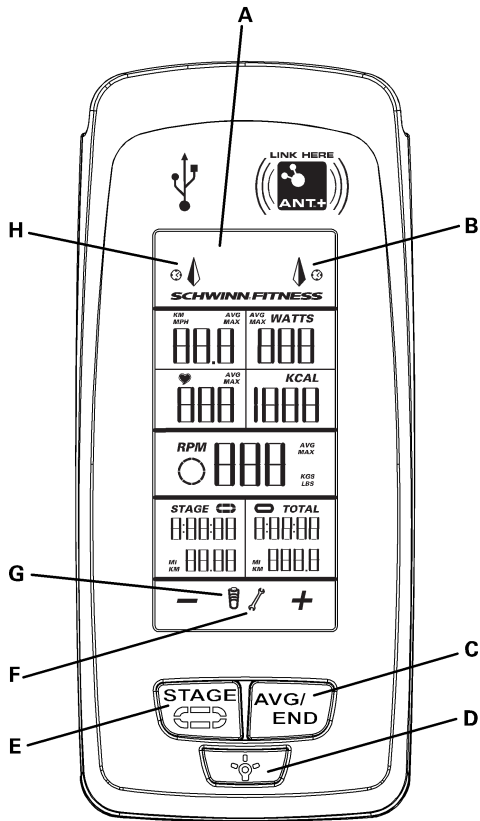

A	Backlit LCD Display	G	Battery Level
B	Ant+ Linking Indicator	H	USB Interface Indicator
C	AVG/END Button (+)	I	Ant+ Transmitter
D	Backlight Button	J	USB Port
E	STAGE Button (-)	K	Battery Bay
F	Maintenance Alert	L	Ant+ Pairing Button

## LCD

The multi-function, backlit LCD shows your workout measurements (during the workout), results, user setup data and console diagnostics.

To turn on the backlight, push the Backlight button. The backlight turns off after 7 seconds to conserve the batteries.

## Heart Rate Monitor

The console gets heart rate data from the heart rate monitor (HRM) to calculate workout data, such as the Calories burned.

The console can read heart rate data from an Ant+ Sport 2.4GHz or Polar® compatible 5kHz wireless chest strap.

## Ant+ Sport 2.4GHz Wireless

The Ant+ Sport 2.4GHz Wireless Heart Rate Monitor (HRM) sends heart rate data to the console after proximity linking occurs during User Setup. The console can read the HRM data to a distance of 118" (3 m) during Workout Mode.

If you have a paired Ant+ Sport Watch and Ant+ HRM, the console links with the sport watch and reads the heart rate data from it.

## Standard EM 5kHz Pulse

The console uses the EM (electromagnetic) 5kHz pulse wireless protocol to read heart rate data from standard heart rate monitors (HRMs), such as a Polar® transmitter chest strap.

## Workout Data Storage

The console sends workout data to the user's data storage device—for example, a USB flash memory device or a sport watch. The console can also get user data from an Ant+ sport watch and use the data to calculate workout results.

## Ant+ Sport Watch

The Ant+ Sport Watch shares user data with the console after proximity linking occurs during User Setup. In User Setup Mode the Ant+ Sport watch sends data (including user weight) to the console. During Workout Mode the console sends workout data to the Ant+ Sport Watch. When proximity linking is complete, the watch and console can send and read data up to 118" (3 m).

## USB Interface / Data Storage

The console can upload workout data to a USB data storage device if the USB port on the console is enabled. To enable the USB port, go to the Service Mode menu. You can connect the USB storage device to the console during User Setup or after the workout ends.

During Workout Mode the console sends these workout data to the USB device:

- Workout (total) — Time, Distance, Calories and average and maximum Speed, Watts, HR and RPM.
- Workout Stages — Time, Distance, Speed, Watts, HR and RPM.

If you connect the USB device after the workout ends, the console only sends the Total Summary data to the USB device.

The USB port also gives access to the Service Technician to export console system data to a USB storage device and to update the console firmware.

## LCD Display Data

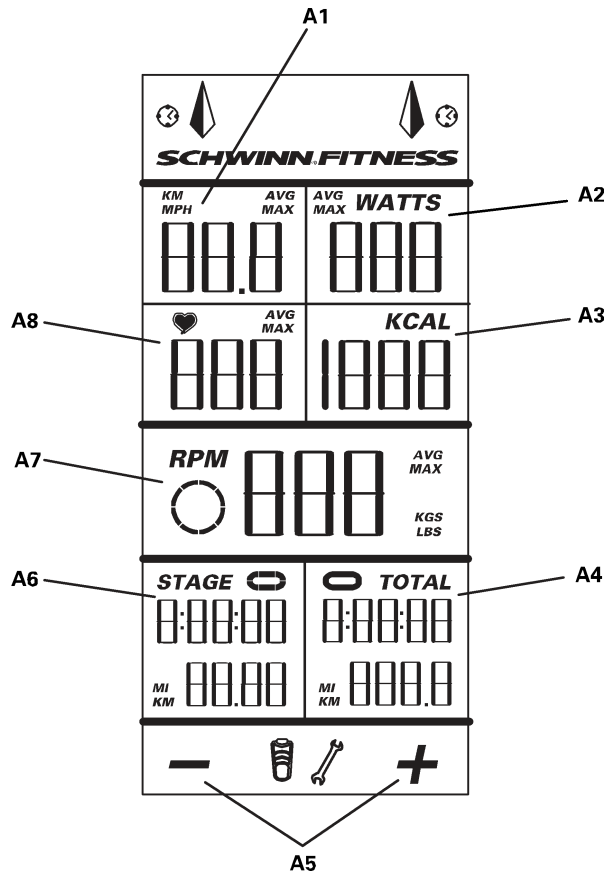

A1	KM / MPH (Speed)	A5	+ / – (Weight Input)
A2	WATTS (Power)	A6	STAGE Time and Distance
A3	KCAL (Calories)	A7	RPM (Cadence)
A4	TOTAL Time and Distance	A8	Heart Rate

**Note:** If you need to change the measurement units to English Imperial or metric, refer to the User Setup section of this manual.

## Speed

The Speed display field shows the estimated speed of the bike in kilometers per hour (KM/H) or miles per hour (MPH).

To view the average speed during Workout Mode, tap the AVG/END button.

## Watts

The WATTS display field shows the power that you are producing at the current resistance level (1 horsepower = 746 watts).

WATTS data only shows if there is a power sensor installed on the bike.

To see the average watts during Workout Mode, tap the AVG/END button.

## Heart Rate

The Heart Rate display field shows the heart rate in beats per minute (BPM) from the heart rate monitor (HRM). The heart icon flashes when the console receiver senses the HRM signal. If the console receiver does not sense the HRM, the center of the heart icon is on solid.

If the console receiver senses an Ant+ HRM signal, there is an outline around the heart icon. The outline does not flash. If the HRM signal is a standard EM 5kHz pulse signal, there is not an outline around the icon.

To see your average heart rate during Workout Mode, tap the AVG/END button.



Consult a physician before you start an exercise program. Stop exercising if you feel pain or tightness in your chest, become short of breath, or feel faint. Contact your doctor before you use the machine again. Use the values calculated or measured by the machine's computer for reference purposes only.

## Calories

The Calories display field shows the estimated calories that you have burned during the exercise.

If the bike does not have a Power Sensor, the console calculates the calories from the heart rate data from the HRM.

## RPM

The RPM display field shows the current pedal revolutions per minute (RPM).

To see the average RPM during Workout Mode, tap the AVG/END button.

For bikes that do not have a Power Sensor installed, the RPM field is also the user weight input field during User Setup Mode. The console will show error messages in this field if an error occurs.

## Workout Stage

The STAGE display field shows the time and distance in the current Stage of the workout. The display values start at zero and count forward until the end of the Stage. At each Stage in the workout, the Stage icon shows the Stage number with the number of segments that are on:

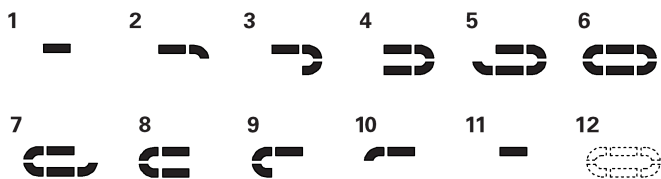

## Workout Totals

The TOTAL display field shows the total time and distance results at the end of the workout. The Total icon is lit during Workout Mode.

## LCD + and – Icons

The + and – (plus and minus) icons on the LCD flash to prompt the user to enter their weight during User Setup Mode. The icons turn off when not in use.

## Keypad

The multi-function keypad lets you set the console measurements for your workout, see and update your workout data, and examine the console diagnostic messages. Tap any button to activate the console from Sleep Mode. The Operations section of this manual gives the procedures for using the buttons in each Operations mode. The Backlight button sets your selections in User Setup Mode and Service Mode.

## Alerts

The Console icons and LCD display messages show the status of the console and sensor operations.

## Battery Level

The Battery Level icon shows the overall battery level for the console-sensor system. All 4 segments of the icon are on when the battery level is high. When the battery level is low, only the bottom segment is on. The bottom segment flashes when battery level is very low.

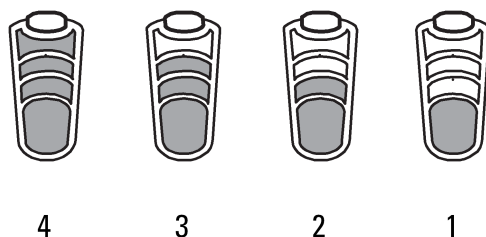

If the system battery level is low, go to the Service Mode menu. Use the AP menu option to see the levels of the console and sensor batteries.

If the battery level is too low to continue operation, the console display flashes the message “LO batt” and the console goes into Sleep Mode. If this occurs during a workout, the workout stops and the console display shows the workout results for 10 seconds. Then the “LO batt” message shows and the console goes into Sleep Mode.

## Maintenance Alert

The Maintenance Alert icon blinks when a maintenance condition occurs. Look for error messages on the LCD display. Refer to the Troubleshooting section of this manual. To go to the Service Mode menu, push the AVG/END and STAGE buttons and hold for 5 seconds.



## Errors

Error messages tell you when there is a problem in the bike's operation:

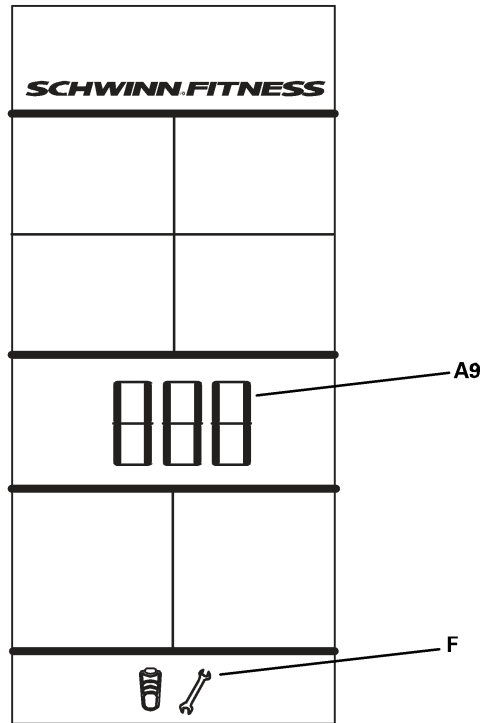

---

A9	Error Message
F	Maintenance Alert icon flashes

---

Refer to the Troubleshooting section of this manual. To go to the Service Mode menu, push the AVG/END and STAGE buttons and hold for 5 seconds. The LCD display is different for Errors that occur during a non-Service Mode (ex: Workout Mode) and Errors during Service Mode.

## Wireless Bike Sensor Data

The console gets bike operation data from the bike's sensors and uses the data to calculate workout results. The console and wireless sensors can transmit data after the Device Pairing process sets up their wireless connection. The Configuration/Service Mode section of this manual gives the Device Pairing procedure. It is easiest to set up Device Pairing before you initially install the console and sensors on the bike.

## Bike Speed Sensor

The Schwinn® MPower™ Console comes with a speed sensor for the bike. The speed sensor transmits data from the flywheel to the console during the workout.

Refer to the Schwinn® MPower™ Console Installation Guide for the procedure to install the speed sensor on the Schwinn A.C.™ bike.

## Power Sensor

The MPower™ Power sensor is an optional upgrade for a Schwinn A.C.™ bike with a Schwinn® MPower™ Console. The power sensor transmits data from the Brake resistance mechanism to the console during the workout.

Refer to the Schwinn® MPower™ Power Upgrade Installation Guide for the procedure to install the power sensor on the Schwinn A.C.™ bike.

# Operations

## Sleep Mode

The console automatically goes into Sleep Mode to conserve the battery:

- if there is no activity for 45 seconds after User Setup.
- after Display Results.
- if Workout Mode pauses and there is no activity for 5 minutes.

Push any button to activate the console from Sleep Mode.

## User Setup

When the console is in Sleep Mode, push any button to go to User Setup mode.

During User Setup Mode the console collects the necessary user data to calculate and record your workout data. Proximity linking to the user's HRM or Ant+ watch occurs while in User Setup.

If the console does not find a USB storage device or Ant+ watch, the arrow icons on the console blink. Use the appropriate instruction for your monitoring equipment.

- USB storage device—install the device in the USB port. When the console senses the device, the USB arrow indicator stays on.



- Ant+ watch—link to the console. Move the watch to 2–4" (5–10 cm) or less from the Ant+ Link Here logo on the console and hold it there until the arrow stays on. The Ant+ arrow and watch indicators come on when proximity linking is complete.



- Ant+ HRM—link to the console. Lean into the console so that the HRM is 7.5–31" (20–80 cm) from the Ant+ Link Here logo, until the arrow stays on. The Ant+ arrow indicator comes on when proximity linking is complete. If the Ant+ indicator is not on, the console uses EM 5kHz signal to calculate HRM.

**Note:** If you have an Ant+ Sport Watch and paired Ant+ HRM, it is only necessary for the the console to link with the sport watch. However, if you have an Ant+ Sport Watch and EM 5kHz HRM, the console links to the watch and the HRM.

Ant+  
Watch

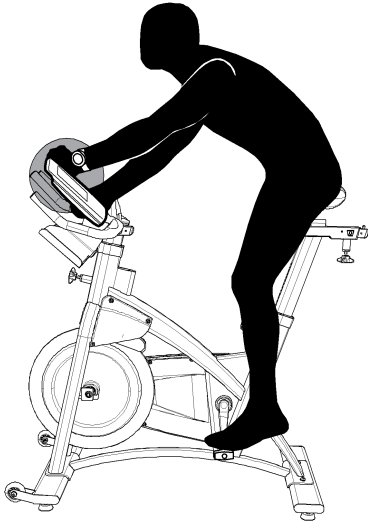

HRM

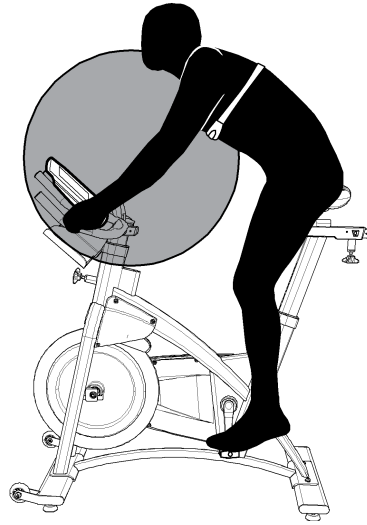

For bikes that do not have a Power Sensor installed, user weight data is necessary to calculate the Calories during the workout. If the console does not get the weight data from a device, you must manually set the weight value. The + and – icons on the LCD flash, and the RPM field displays 170 lbs. (80 kg). Use the STAGE (–) and AVG/END (+) buttons to adjust the number to your weight.

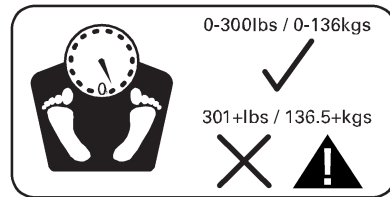

**Note:** To change the weight units to English Imperial or metric:

- Push the STAGE and AVG/END buttons for 5 seconds to go to Service Mode.
- Tap the AVG/END button until you see the UN menu option, and push the Backlight button.
- Push the STAGE or AVG/END button to see the UN menu options—UN0 (metric) and UN1 (Imperial). Push the Backlight button to set the units measure.
- The console goes back to the Service Mode menu and the UN menu option appears. Tap the STAGE or AVG/END button until you see the “--” (exit) option in the Service Menu.
- Push the Backlight button to go back to User Setup Mode.

Push the Backlight button to record your weight.

During User Setup (while RPM is less than 80), it is possible to lose the proximity linking to an Ant+ watch or Ant+ HRM if you move too far away from the Console. If this occurs for the Ant+ watch, the Ant+ watch indicator flashes. If this occurs for the Ant+ HRM, the HR display field shows 0 (zero). You must do the proximity linking procedure again.

If Workout Mode does not start in 45 seconds, there is no keypad activity and RPM is less than 5, the console returns to Sleep Mode.

## Workout Mode

After User Setup is complete, start pedaling the bike. When the Cadence RPM increases to 80 RPM or more, the console goes into Workout Mode. The Workout STAGE and TOTAL icons come on and the workout measurements start.

**Note:** If proximity linking was not complete in User Setup, the console can still link with the Ant+ sport watch and HRM during the first 30 seconds of Workout Mode.

Tap the AVG/END button to see your average data values (AVG). The average values show for 5 seconds. To go back to current measurements more quickly, tap the AVG/END button again.

When the Cadence decreases to less than 5 RPM for 3 seconds or more, the console pauses and the LCD Display shows the last workout data values. If you stay paused for more than 5 minutes, the workout stops and the console goes to Display Results mode.

To set the STAGE time and STAGE distance back to zero for a new stage in the workout, tap the STAGE button. The TOTAL time and TOTAL distance continue the total measurement for the workout.

To end the workout, push the AVG/END button and hold for 3 seconds. The console goes to Display Results mode.

## Display Results

To stop the workout and go to Display Results Mode, push the AVG/END button and hold it for 3 seconds or longer. The console shows total Calories, TOTAL time and distance, and the Max and Average values for Speed, Watts, Heart Rate and RPM. The Max values show first for 5 seconds. Tap the AVG/END button to change between Max and Average values. After 1 minute, the console sets the values back to zero and goes into Sleep Mode.

Push the AVG/END button and hold for 3 seconds to stop Display Results Mode and go to Sleep Mode.

## Device Pairing

Set up Device Pairing for the Console, the Speed Sensor and the Power Sensor (if applicable) before you install them on the bike. If you add the Power Sensor upgrade to a bike that already has the Console and Speed Sensor installed, it is necessary to set up Device Pairing again for the console and the 2 sensors. It is necessary to remove the console and sensor from the bike for access to the pairing buttons.

1. Make sure the batteries are in the console (K1) and the sensors (K2 and K3, if applicable).

Console

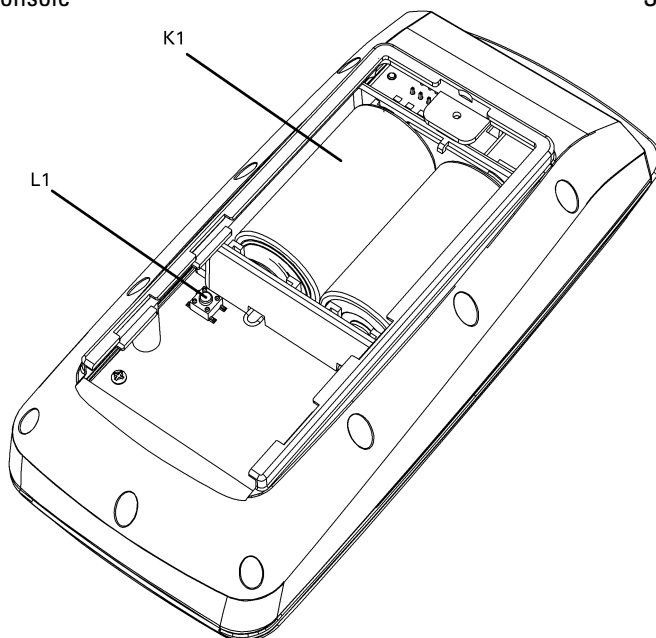

Speed Sensor

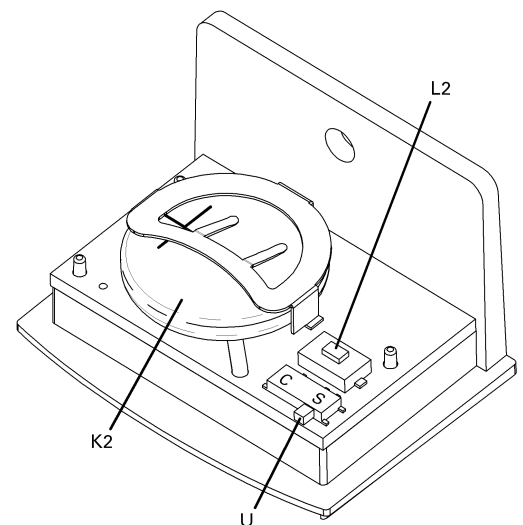

Power Sensor

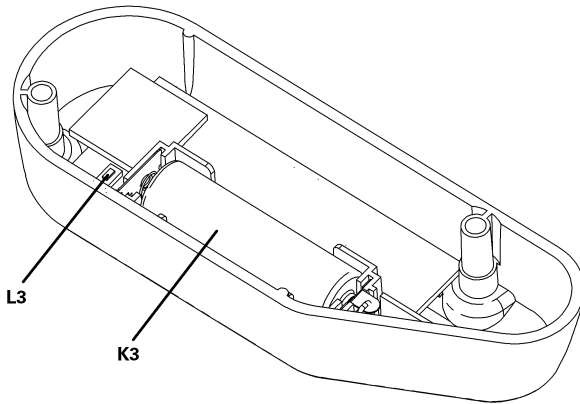

2. Push the STAGE and AVG/END buttons for 5 seconds to go to Service Mode.
3. Tap the AVG/END button until you see the **P-** menu option, and push the Backlight button.
4. Push the STAGE or AVG/END button to see the P-- submenu options—PE0 (not power enabled) and PE1 (power enabled).
  - If you have a Power Sensor, go to the PE1 option and push the Backlight button to set PE (power enabled).
  - If there is no Power Sensor, go to the PE0 option and push the Backlight button to set NPE (not power enabled).
5. The console goes back to the Service Mode menu and the **P-** menu option appears.
6. Make sure that the switch (U) on the Speed Sensor is set to **S** (speed).
7. Push the pairing buttons on the Console (L1), the Speed Sensor (L2) and the Power Sensor (L3), if applicable.
8. The console display shows PPP and the time display counts down from 0:35 (seconds).

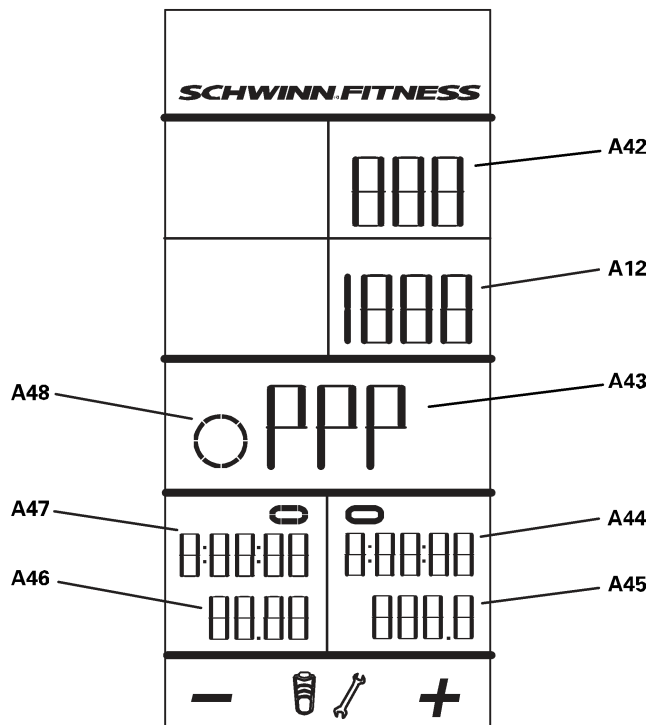

A12	Error Message	A45	Process Status (Speed Sensor)
A42	Power Configuration (PE/NPE)	A46	Process Status (Power Sensor)
A43	Pairing	A47	Countdown Timer (Power Sensor)
A44	Countdown Timer (Speed Sensor)	A48	Pairing Indicator

9. The Process Status indicator(s) on the console display shows “--” while the Pairing operation continues.

If Pairing is completed satisfactorily, the console display shows PASS.

The circuit board inside the Power Sensor cover has 2 color LEDs — 1 green and 1 red. The 2 LEDs come on during the Pairing operation. While the operation continues satisfactorily, the green LED is on. When Pairing is completed satisfactorily, both LEDs turn off. If the Pairing operation is not completed satisfactorily, only the red LED stays on.

If the Pairing operation is not completed satisfactorily, the console display shows FAIL. Push the pairing button on the console (L1). Then do the Device Pairing procedure again.

10. When the Pairing procedure is completed, push the Backlight button to go back to the Service Menu.

If the Pairing operation was not completed satisfactorily, the console display shows the **P-** menu option again. Push the pairing button on the console (L1). Then do the Device Pairing procedure again.

11. Tap the STAGE or AVG/END button until you see the “--” (exit) option in the Service Menu, and push the Backlight button.

12. Install the console and sensors on the bike. Refer to the MPower™ installation guides.

## Device Pairing for Multiple Bikes

For Schwinn A.C.™ bikes with MPower™ Consoles in a group setting, make sure to set up Device Pairing for only one bike at a time to prevent crosstalk between the devices on different bikes.

**NOTICE:** When you remove the handlebars (with console) to clean them, make sure that you install them again on the same bike to keep the Device Pairing correct. If you install the handlebars and console on a different bike, the console does not read data from the correct sensors.

**Recommendation:** You can put number labels on the bikes and handlebars to make sure that the Device Pairing stays correct.

## Configuration / Service Mode

The Service Mode menu lets Service Technicians set the bike configurations, see maintenance data, do calibrations and upgrade the console firmware. Access to Service Mode is available when the console is in User Setup Mode:

- Push the STAGE and AVG/END buttons for 5 seconds to go to Service Mode.
- Tap the AVG/END or STAGE button to look at the Service Mode menu options.
- Push the Backlight button to make your selection and go to the submenu options.
- Tap the AVG/END or STAGE button to look at the submenu options.
- Push the Backlight button to set the correct option.
- The console goes back to the Service Mode menu and the current menu option appears.

**Note:** If the Exit option does not let you out of the Service Menu option, there is possibly a Pairing problem with the console or one of the sensors.

- Tap the STAGE or AVG/END button until you see the “--” (exit) option in the Service Menu.
- Push the Backlight button to go back to User Setup Mode.

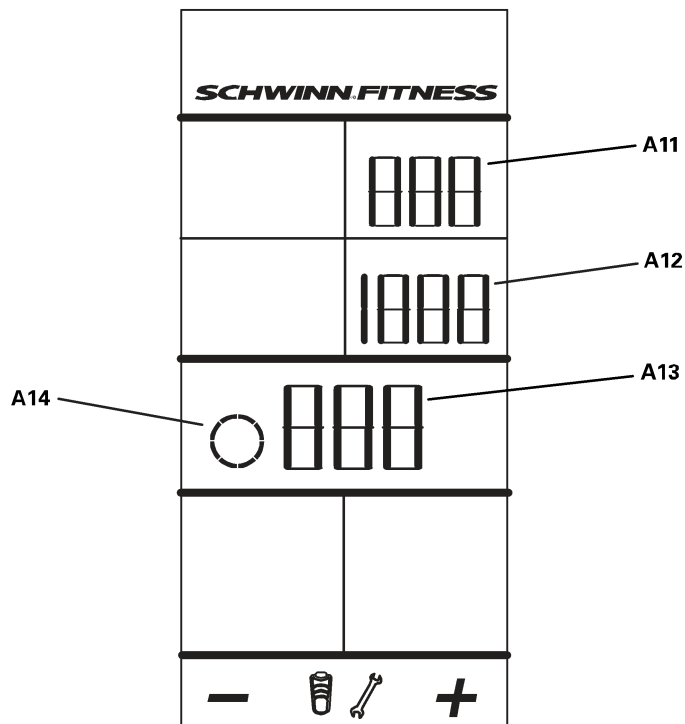

---

A11 Current Submenu Option

A13 Current Service Mode Menu Option

A12 Error Message

A14 Menu Number Indicator

---

## Bike Level Type

The **L** option in the Service Mode menu is not currently used.

## Unit Measures (English/Metric)

The **UN** option in the Service Mode menu sets the Unit Measures for weight, speed and distance to UN0 (metric) or UN1 (English Imperial).

## Power

The **P** option in the Service Mode menu sets the Power configuration to: PE0 (not power enabled–NPE) or PE1 (power enabled–PE). Set the value to PE if there is a Power Sensor on the bike. The default value is NPE.

## Power Calibration

The power calibration options in the Service Mode menu are only for bikes that have the Power Sensor upgrade installed.

Go to the **C-** option in the Service Mode menu to do calibrations of the Power Sensor: C01 (Tilt Sensor), C04 (Functionality Test) and C05 (Auto Calibration). The C02 and C03 menu options are not available.

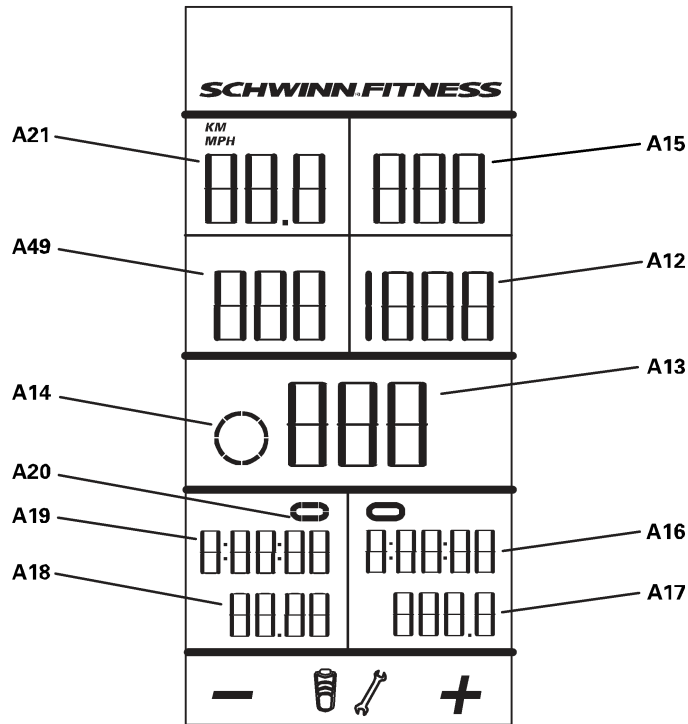

A12	Error Message	A18	Required Angle
A13	Current (Sub) Menu Option	A19	Countdown Timer
A14	Menu Number Indicator	A20	Calibration Stage Indicator
A15	Calibration Stage	A21	Current Angle
A16	Process Status	A49	Current RPM
A17	Device ID / Required RPM		

**Note:** Display fields can show different data for different calibration procedures or for different stages in a calibration procedure.

## Tilt Sensor Calibration

The **C01** option in the Power Calibration submenu lets you do the Tilt Sensor Calibration. After you go to the C01 option and push the Backlight button, the console does a check of the Power Sensor to get the calibration status and requirements.

Tilt Sensor Calibration has 3 stages: Stage 1 (Full Up Position – “UP”), Stage 2 (Full Down Position – “dn”) and Stage 0 (Zero G Calibration – “0G”). The Tilt Calibration sub-submenu options are UP, dn, 0G and “--” (exit).

**NOTICE:** Full Up Position is the only Tilt Sensor Calibration that is used. When you do the initial installation of the Power Sensor, do the Full Up Position calibration.

If you move the bike after Tilt Sensor Calibration is done, do the Full Up Position calibration again to correct errors caused by differences in the floor level.

- Tap the AVG/END or STAGE button to look at the Stage options.
- Push the Backlight button to make your selection.

**Note:** To stop the calibration at any point, push and hold the AVG/END button for 3 seconds.

## Full Up Position Calibration

**NOTICE:** The Power Sensor must be installed on the bike for the Full Up Position calibration. Refer to the Schwinn® MPower™ Power Upgrade Installation Guide.

- If the Power Sensor is not installed on the bike, install it on the bike. Refer to the Schwinn® MPower™ Power Upgrade Installation Guide.
- Tap the AVG/END or STAGE button to go to the **UP** (Stage 1) option.
- Turn the Brake Adjustment Knob to the farthest left position (–) to raise the Brake Carriage to the Full Up Position.



- After the Brake Carriage is stable for 3–4 seconds, push the Backlight button.
- The timer starts to count down.
- Look for the result from the Power Sensor on the console display. The message “PASS” shows if the calibration result is satisfactory. The message “FAIL” shows if the timer counted down to zero and the calibration result is unsatisfactory.

## Functionality Test

The **C04** option in the Power Calibration sub-menu is only for the Service Technician to check the quality of radio frequency (RF) reception.

## Auto Calibration

The **C05** option in the Power Calibration sub-menu sets the Auto Calibration function. Auto Calibration lets you make sure that the Watts reading is accurate. After you go to the C05 option and push the Backlight button, the console shows the status of the Auto Calibration function: ON (enabled) or OFF (disabled). Push the Backlight button to go into the CAL sub-submenu option.

**NOTICE:** Device Pairing and Tilt Sensor Calibration for the bike must be completed before you do Auto Calibration.

1. Tap the AVG/END or STAGE button to go to the **ON** option.
2. Push the Backlight button to make your selection. The Power Sensor must come on before the calibration can continue. When the Power sensor is off, the Angle display field shows “— — —”. When the Power Sensor comes on, the display shows the message “PUSH”.

**Note:** If the console does not receive data from the Power Sensor for more than 5 seconds, the calibration test stops. Start the calibration again.

3. Push the Backlight button and the PUSH prompt goes off. The timer starts to count down. The Current Angle display should show “00.0” one time.
4. Look for the result from the Power Sensor on the console display:
  - The message “PASS” shows if the calibration result is satisfactory. The Console is ready to start Workout Mode.
  - The message “rEdo” shows if the timer counted down to zero and the calibration result is unsatisfactory. If the calibration result is still unsatisfactory after 2 times, the message “ridE” shows and the Console goes to User Setup mode.

When Auto Calibration is enabled, the console automatically does a check of the Power Sensor every time the console is turned on. The Power Sensor must come on before the calibration occurs.

**CAL:**

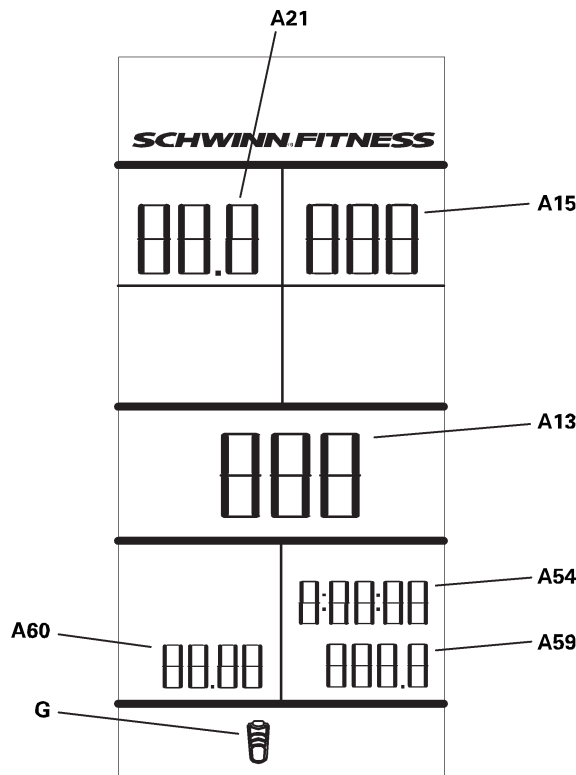

A13	Current (Sub) Menu Option	A59	Process Status
A15	Calibration (Stage) Setting	A60	PUSH Backlight Prompt
A21	Current Angle	G	Battery Level
A54	Timer		

**Battery Level Status**

The **AP** option in the Service Mode menu lets you inspect the levels of the batteries in the console and sensors through the submenu options: AP1 (Console), AP2 (Speed Sensor) and AP3 (Power Sensor). When you go into the AP menu option, the console shows the level of the lowest battery in the console-sensor system.

**AP-:**

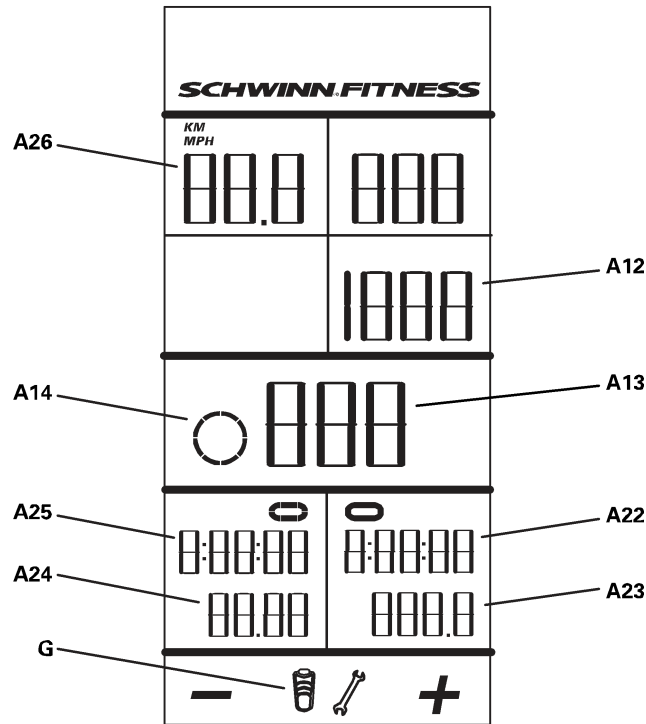

A12	Error Message (Current / Last)	A24	Device ID
A13	Current (Sub) Menu Option	A25	Device Name
A14	Menu Number Indicator	A26	Numeric Level
A22	Total Operation Time (if applicable)	G	Battery Level icon
A23	Current Voltage Level (if applicable)		

**Total Operation Time:**

For Speed Sensor and Power Sensor only.

**Current Voltage Level:**

For Console and Power Sensor only.

**Device Name:**

Type of device—"Batt" (system), "CONSL" (console), "P:SenS" (power sensor), "SPEEd" (speed sensor).

**Numeric Level:**

The LCD shows a value of 00.0–99.9 (low to high) as a percentage of battery life.

**Battery Level icon:**

All 4 segments of the icon are on when the battery level is high. When the battery level is low, only the bottom segment is on and the icon flashes.

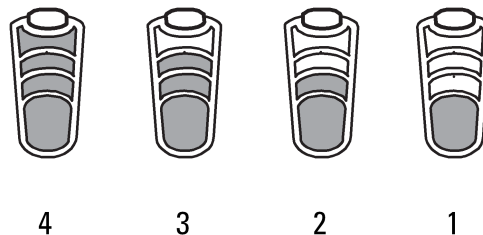

When you select the submenu option for a specific battery (AP1, AP2 or AP3), the console shows the level of that battery:

Battery Status Icon	Console	Speed Sensor	Power Sensor Voltage
4 segments	80–100%	80–100%	1.5V or more
3 segments	60–80%	60–80%	1.3–1.499V
2 segments	40–60%	40–60%	1.1–1.299V
1 segment	20–40%	20–40%	0.9–1.099V
1 segment flashing	less than 20%	less than 20%	less than 0.9V

If the battery level is low, refer to the instructions for battery replacement in this manual.

## Console Status

The **EP** option in the Service Mode menu lets you inspect maintenance data in the console and adjust settings in the EEPROM firmware through the submenu options:

- EP0—Console setup summary
- EP1—Console “Reset” function for technician to update the firmware.
- EP2—Active speed option lets you change the 80 RPM threshold (default value) for the console to start Workout Mode.
- EPN—Cumulative workout statistics for RPM and Power
- EPE—Erase EEPROM to set console back to defaults and erase device pairing.
- EPr—Error history
- EPb—Backlight options
- “--” —Exit

### EP0:

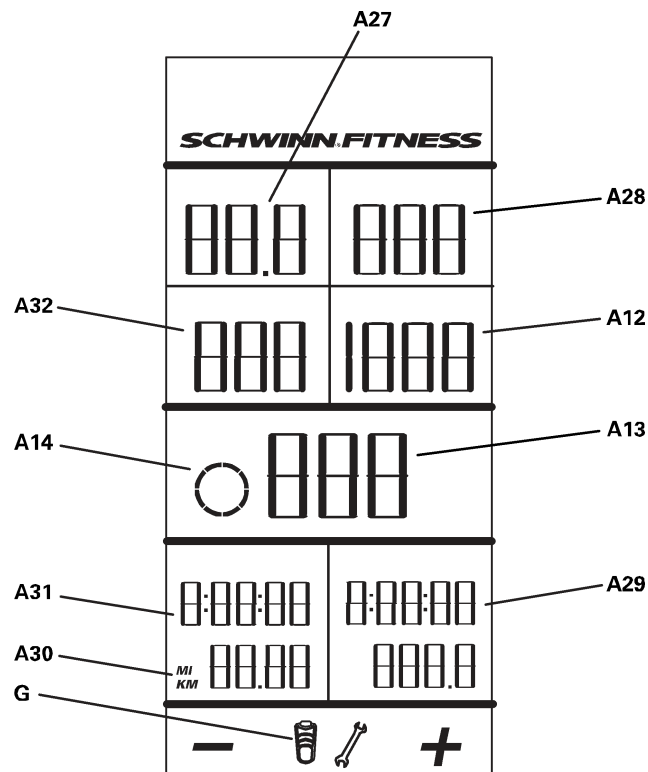

A12	Error Message	A29	Total Run Hours
A13	Current (Sub) Menu Option	A30	Units—Metric/English Imperial
A14	Menu Number Indicator	A31	Odometer
A27	Firmware Version for Console	A32	Power Configuration (PE/NPE)
A28	Firmware Version for Power Sensor	G	Battery Level

**Error Message:**

Current error message shows as “Exx”. If there is no error (current operation is completed correctly), the display shows “- - -”.

**Odometer:**

The top display field shows the number of calculated miles/km, up to the maximum value of 99999. If the total distance is more than 99999, the top field shows the remainder of the distance. The lower field shows “ODOx” with x equal to the number of times the maximum value occurred. If x = 0, the display shows “ODO”. For example: “100001” shows as “2” in the top field and “ODO1” in the lower field.

**EPN:**

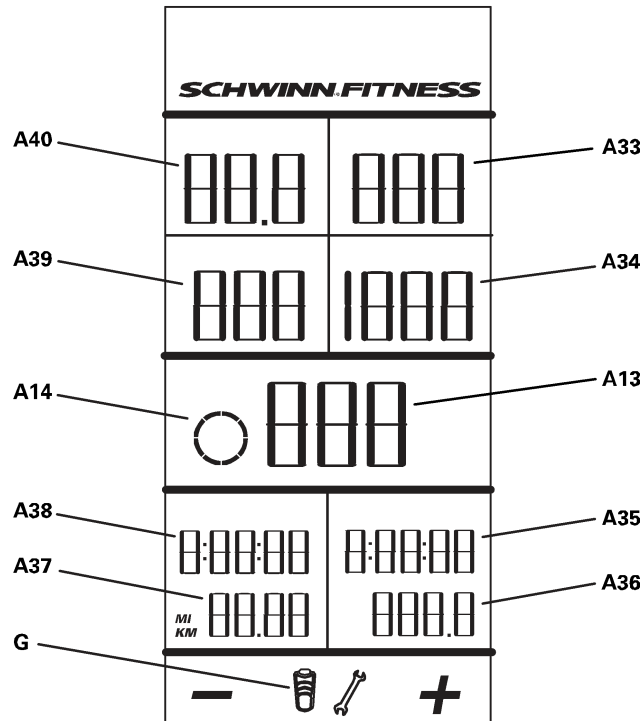

A13	Current (Sub) Menu Option	A37	Max RPM Threshold
A14	Menu Number Indicator	A38	Count Max RPM
A33	Average Power	A39	Maximum RPM
A34	Maximum Power	A40	Average RPM
A35	Count Max Power	G	Battery Level
A36	Max Power Threshold		

Display fields for Power statistics show “ - - ” if the bike is NPE.

- Maximum Power:** Maximum power value recorded from all workout data.
- Count Max Power:** Number of times that a power value more than the Max Power Threshold (999 watts) occurred.
- Max Power Threshold:** **999** (watts).
- Maximum RPM:** Maximum RPM value recorded from all workout data.
- Count Max RPM:** Number of times that an RPM value more than the Max RPM Threshold (110 RPM) occurred.
- Max RPM Threshold:** **110** (RPM).

**EPr:**

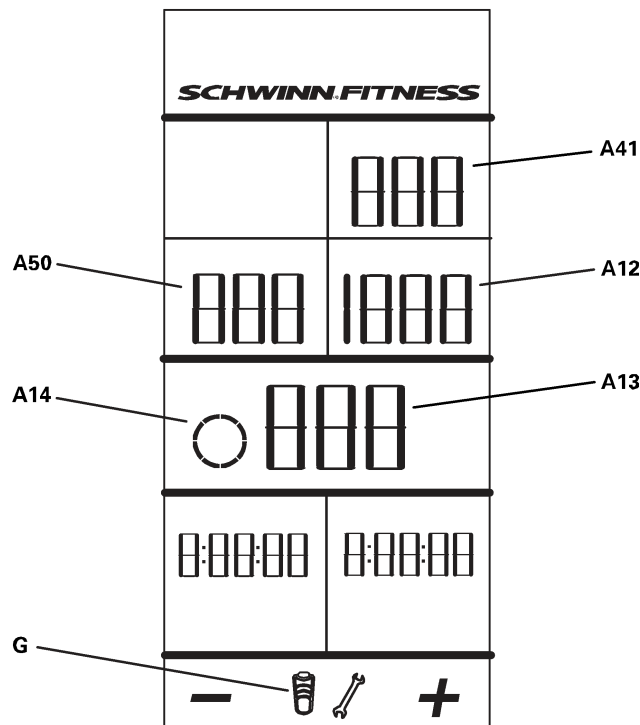

A12	Error Message	A41	Error Count
A13	Current (Sub) Menu Option	A50	Error Sequence
A14	Menu Number Indicator	G	Battery Level

- Error Message:** The error message shows as “Exx”. If there is no error (current operation is completed correctly), the display shows “ - - ”.
  - Error Count:** Number of times that the error occurred.
  - Error Sequence:** Sequence in error history – 1 is newest; 10 is oldest.
- Tap the STAGE or AVG/END button to look through the sequence of error messages in the error history.
  - Push and hold the AVG/END button for 3 seconds to clear the Error Count for the specified error message.

- To clear all Error Counts, push and hold the AVG/END button for 3 seconds when you are at the submenu EPr, before you go to a specific error.
- You can acknowledge Power Sensor Calibration errors so that the Error Message does not show until battery replacement or the console restarts. Push and hold the STAGE button for 3 seconds. The Error Message will only show in the EPr display.

**EPb:**

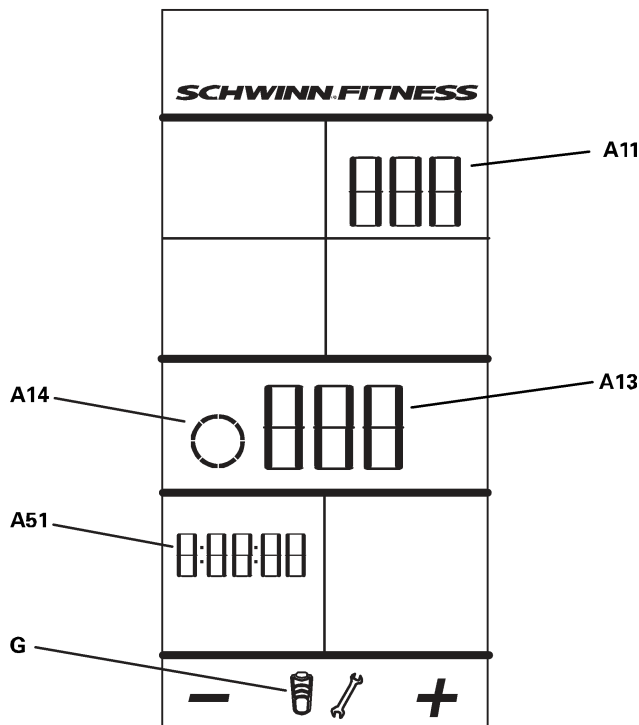

A11	Submenu option	A51	Backlight option (Time/On/OFF)
A13	Current (Sub) Menu Option		

**Number (Time):**

Sets the operation so that you must push the Backlight button to turn on the backlight. You set the number of seconds that the backlight stays on before it turns off to conserve the batteries. The range for the time values is 1–20 seconds.

**ON:**

Sets the operation so that the backlight comes on and stays on when the console is on.

**OFF:**

Sets the operation so that the backlight stays off when the console is on.

**USB Enabling**

The **U-** option on the Service Mode menu sets the USB function to: U01 (Disabled – workout data not saved), U02 (Enabled – save workout data) or U03 (Export Data). The default value is U02.

The Export Data option is only for the Service Technician to download system data (EP0 and EPN display data) to a USB device.

**Data Export to USB Storage Device**

To record the console system data on a USB storage device, connect the USB device to the console and go to the **U03** option

(Export Data) on the **U**- - submenu. The Export Data option sends the EP0 and EPN display data to a USB storage device as a file in .CSV format. If the Service Technician exports and stores data from multiple bikes to the USB device, the data for each new system is added to the end of the file.

**Sample Data Format:**

Console Firmware	x.x		
Power Sensor Firmware	XX		
Speed Sensor Firmware	XX		
Power Device ID	13089		
Speed Device ID	12		
Bike Number	(n/a)		
Console Battery Level	3.2		
Power Battery Level	1.1		
Speed Battery Level	80 (percent)		
Bike Type	L01		
Pair Type	PE		
UNITS	US		
Errors:	E01	E09	E10
Error Count	2	5	7
Errors Ignored	E06	E09	
Current ERROR	0		
Total Workout Hours	141.343		
Total Distance	4242.245		
Average RPM	86.6		
Average Power	150.9		
Max RPM	135		
Max Power	456		
Thresholds Power	999		
Threshold RPM	110		
Threshold Power Count	1		
Threshold Speed Count	2		

# IC Class Setup

To use Schwinn A.C.™ bikes with MPower™ consoles in a group setting, make sure to leave sufficient space between the bikes to prevent interference in the proximity linking of the console and the rider's HRM and Ant+ Sport Watch. Refer to the IC class floorplan below for the distance between bikes.

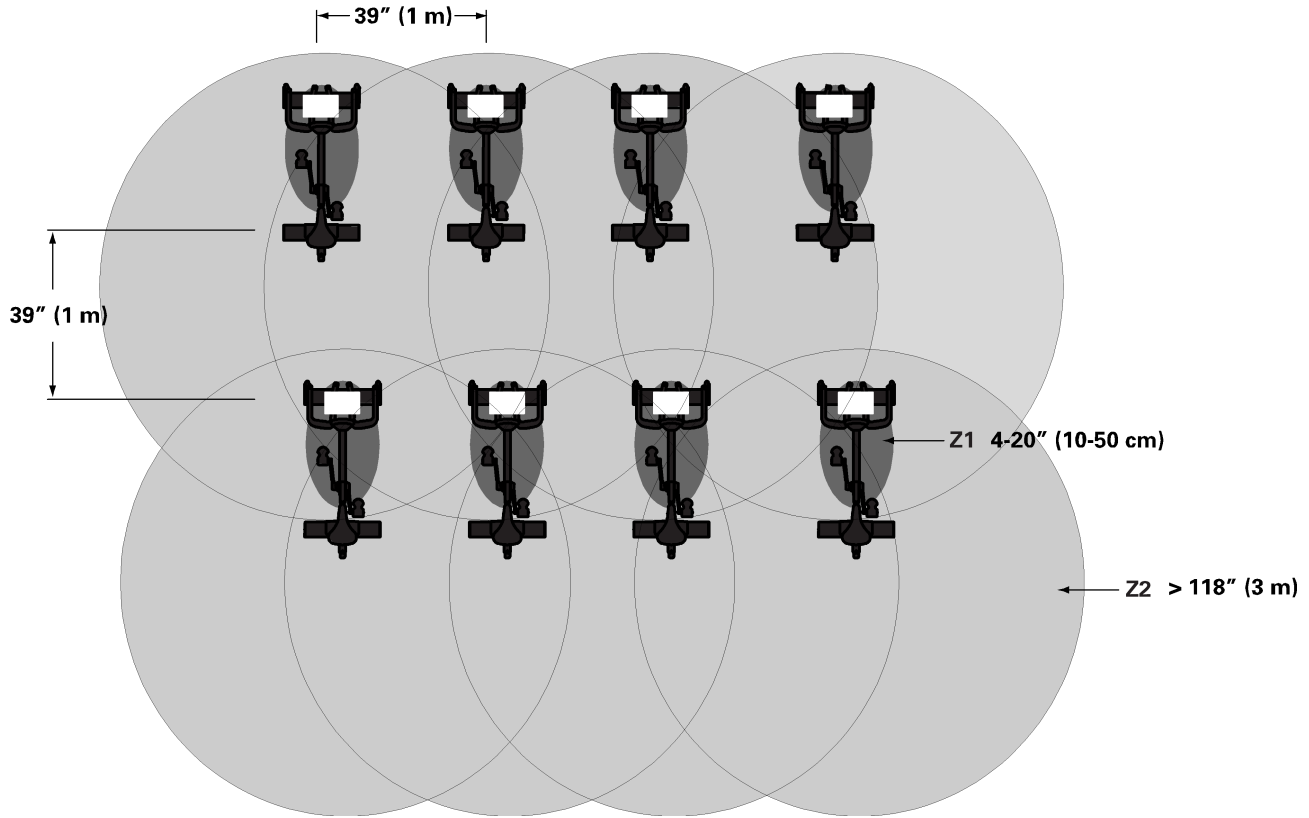

Z1	The proximity linking zone for the console and the HRM and Ant+ Sport Watch and HRM.
Z2	The tracking zone for the console to sense the HRM and Ant+ Sport watch after proximity linking is complete.

**Note:** The tracking zone for an EM 5kHz HRM is approximately 28" (70 cm).

# Troubleshooting

Condition/Problem	Check	Solution
Console does not come on	No batteries or dead batteries	Replace batteries.
Speed display is not accurate	Display set to wrong unit of measure. (English/Metric)	Go to Service Mode menu and change the Units configuration.
Power display is not accurate	Range of Watt values	Do the Full Up Position calibration. If the power display is still not accurate, replace the Power Sensor.
No Speed display	Speed Sensor	Make sure Speed Sensor is installed. Make sure that the Speed Sensor can sense the magnet in the flywheel. Replace Speed Sensor battery.
No Power display	Power Sensor	Make sure Power Sensor is installed. Replace Power Sensor battery.
No Heart Rate display while using chest strap	Transmitter contact with skin	Moisten skin contact area on the chest strap.
	Electromagnetic interference	Turn off any television, AM radio, microwave, or computer within 6 feet (2 meters) of the bike.
	Chest strap transmitter	Test chest strap with another HRM device such as HR watch or a machine at a gym. If transmitter has good skin contact and still does not send a HR signal, replace chest strap transmitter.
	HR receiver	If chest strap is known to work with other devices and no sources of interference are present, or console is tested with a Pulse Simulator and does not receive the signal, contact Nautilus Customer Care.

**Note:** The LCD display is different for Errors that occur during Service Mode and Errors during non-Service Mode.

Error Code	Condition/Problem	Solution
E00	Console did not pair with Speed Sensor correctly. (This error only occurs after Device Pairing was not completed satisfactorily.)	Push the pairing button on the back of the Console, Speed Sensor and Power Sensor (if applicable) and try the Device Pairing procedure again.
		Replace all batteries, and try the Device Pairing procedure again.
E01	Console did not pair with Power Sensor correctly. (This error only occurs after Device Pairing was not completed satisfactorily.)	Push the pairing button on the back of the Console, Speed Sensor and Power Sensor (if applicable) and try the Device Pairing procedure again.
		Replace all batteries, and try the Device Pairing procedure again.

E02	Power Sensor did not pair with Speed Sensor correctly. (This error only occurs after Device Pairing was not completed satisfactorily.)	Push the pairing button on the back of the Console, Speed Sensor and Power Sensor (if applicable) and try the Device Pairing procedure again.  Replace all batteries, and try the Device Pairing procedure again.
E03	Battery low on Console or Speed Sensor	Do a Battery Level check.
	Interference from the adjacent area	Turn off any television, AM radio, microwave, or computer within 6 feet (2 meters) of the bike, or move the bike.
E04	Battery low on Console or Power Sensor	Do a Battery Level check.
	Interference from the adjacent area	Turn off any television, AM radio, microwave, or computer within 6 feet (2 meters) of the bike, or move the bike.
E05	(not used)	
E06	(not used)	
E07	Tilt Sensor Calibration was not done.	Go to Service Mode menu, <b>C-</b> - submenu, <b>C01</b> option. Call Nautilus Customer Care.
E08	Tilt Sensor Calibration is incorrect or out of date.	Go to Service Mode menu, <b>C-</b> - submenu, <b>C01</b> option. Call Nautilus Customer Care.
E09	USB disabled due to low battery	Replace Console batteries, and go to Service Mode, <b>U-</b> - submenu, <b>U02</b> option.
E10	No signal from Power Sensor	Change the Brake position and pedal the bike for a few seconds to turn on the Power Sensor.
E11	(not used)	
E12	EEPROM error	Remove the console batteries and install them again. If that does not work, call Nautilus Customer Care.
E13	Power Sensor is paired to the wrong Speed Sensor.	Do the Device Pairing procedure again.
E14	Console wireless module not able to transmit/receive	Replace console. Call Nautilus Customer Care.

# Maintenance



Equipment must be regularly examined for damage and repairs. The owner is responsible to make sure that regular maintenance is done. Worn or damaged components must be replaced immediately or the equipment removed from service until the repair is made. Only manufacturer supplied components can be used to maintain and repair the equipment.



This product, its packaging, and components contain chemicals known to the State of California to cause cancer, birth defects, or reproductive harm. This Notice is provided in accordance with California's Proposition 65. If you would like additional information, please refer to our Web site at [www.nautilus.com/prop65](http://www.nautilus.com/prop65)



Before each use, inspect the exercise machine for loose, broken, damaged, or worn parts. Do not use if found in this condition; repair or replace all parts at the first sign of wear or damage. After each use, use a damp cloth to wipe your equipment and computer free of sweat.

**Important:** To avoid damaging the finish on your bike and console, never use a petroleum-based solvent when cleaning. Avoid getting excessive moisture on the console.



Replace the batteries every 1 year (as necessary):

- Console — (2) C batteries (LR14)
- Speed Sensor — (1) CR2032 battery
- Power Sensor (if installed) — (1) AA battery (LR6)

## Replacing the Console Batteries

If you need to replace the batteries in the console:

- Remove the screw that attaches the end of the console bracket to the back of the console.
- Move the console up along the console bracket to open the battery bay.
- Remove the old batteries.
- Put the new batteries in the console. Make sure that they point in the correct direction (+ and -).
- Move the console down the console bracket to close the battery bay.
- Attach the console to the console bracket with the screw.

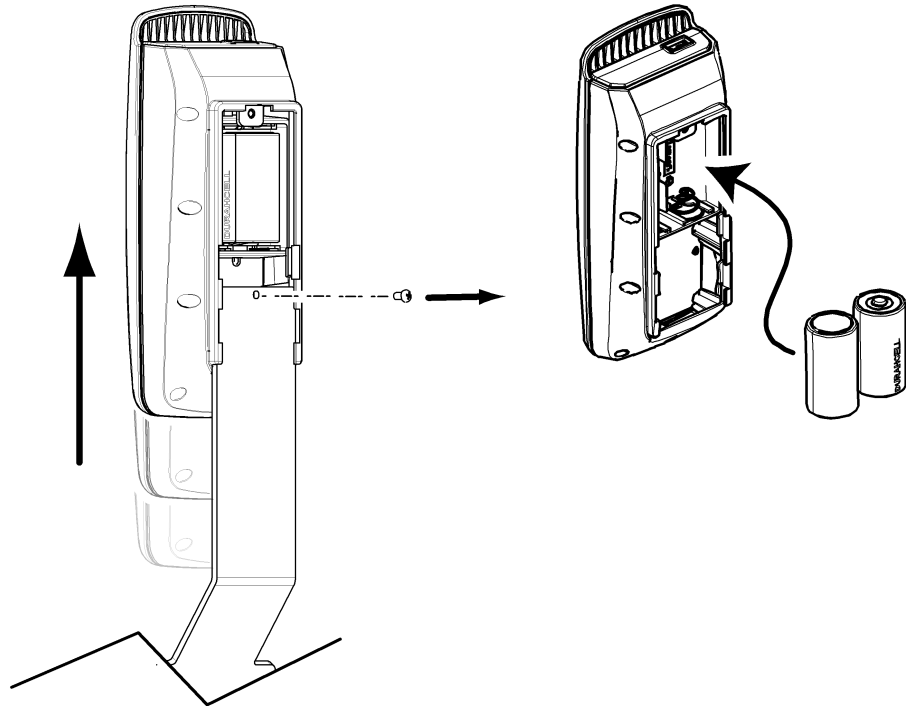

## Replacing the Speed Sensor Battery

If you need to replace the batteries in the speed sensor:

- Remove the 2 screws that attach the speed sensor to the front of the chainguard.
- Remove the small screw that attaches the inner sensor housing to the outer housing.
- Slide the inner housing off the outer housing. The battery holder is in the inner housing.
- Carefully slide the old battery out of the battery holder.
- Carefully slide the new battery into the battery holder. Make sure that you can see the + icon on the battery.
- Install the inner sensor housing to the outer housing with the small screw.
- Attach the sensor to the chainguard with the 2 screws.

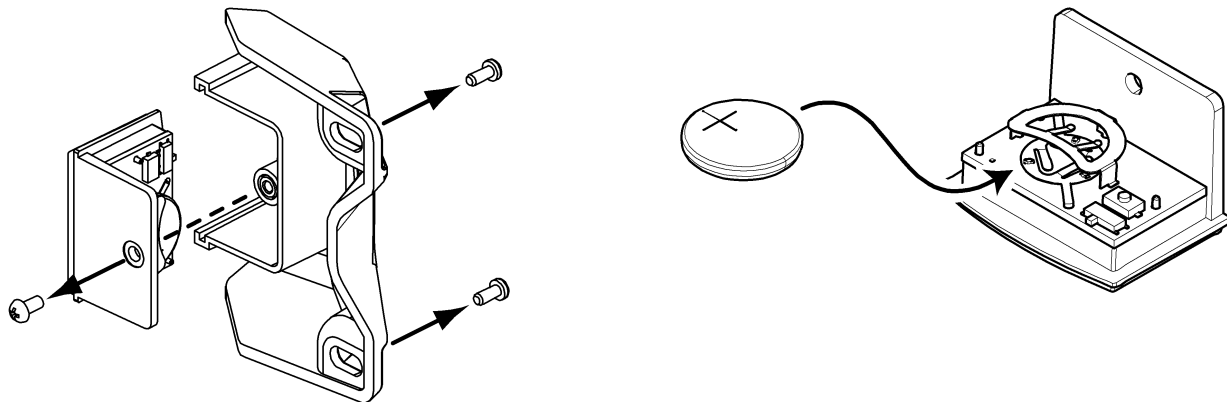

## Replacing the Power Sensor Battery

This procedure is only for bikes that have the Power Sensor upgrade installed.

If you need to replace the batteries in the Power Sensor, refer to the Schwinn® MPower™ Power Upgrade Installation Guide:

- Remove the 2 screws that attach the Power Sensor to the Brake Carriage.
- Remove the gasket from the outer sensor housing.
- Remove the old battery from the battery bay.
- Put the new battery in the battery bay. Make sure that it points in the correct direction (+ and -).
- Put the gasket back on the outer housing .
- Attach the Power Sensor to the Brake Carriage with the 2 screws.

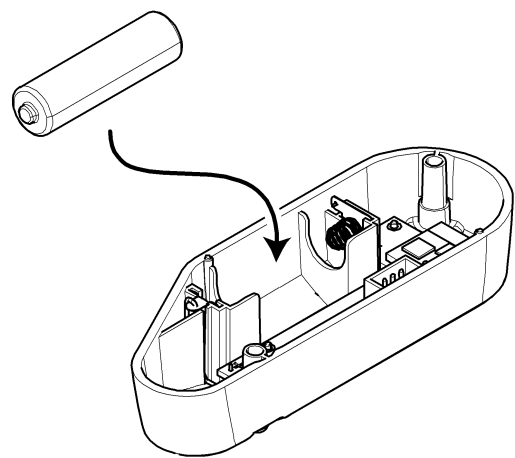
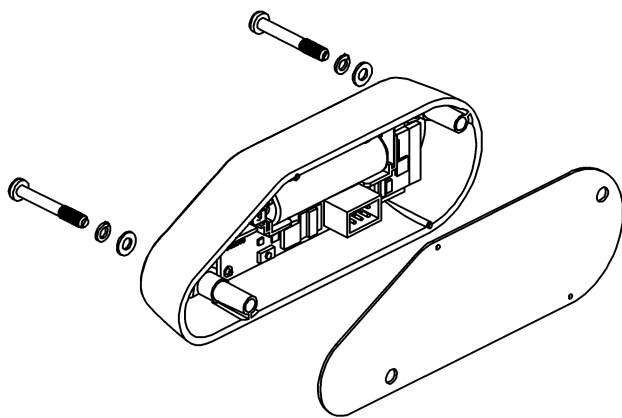

# Contacts

## **NORTH AMERICA**

### **CUSTOMER SERVICE**

Tel: (800) 605-3369

E-mail: customerservice@schwinnfitness.com

### **CORPORATE HEADQUARTERS**

Nautilus, Inc.

World Headquarters

16400 SE Nautilus Drive

Vancouver, WA, USA 98683

Tel: (800) NAUTILUS (628-8458)

## **ASIA PACIFIC & LATIN AMERICA**

### **CUSTOMER SERVICE**

Tel: (360) 859-5180

Fax: (360) 859-5197

E-mail: technics-APLA@nautilus.com

<b>Serial Number</b>
<b>Date of Purchase</b>

## **EUROPE, MIDDLE EAST & AFRICA**

### **INTERNATIONAL CUSTOMER SERVICE**

Nautilus International GmbH

Albin-Köbis-Str. 4

51147 Köln

Tel: + 49 02203 2020 0

Fax: + 49 02203 2020 45 45

E-mail: technics@nautilus.com

### **GERMANY and AUSTRIA**

Nautilus International GmbH

Albin-Köbis-Str. 4

51147 Köln

Tel: + 49 02203 2020 0

Fax: + 49 02203 2020 45 45

### **SWITZERLAND**

Nautilus Switzerland SA

Rue Jean Prouvé 6

CH-1762 Givisiez

Tel: + 41 26 460 77 66

Fax: + 41 26 460 77 60

### **UNITED KINGDOM**

Nautilus UK Ltd

4 Vincent Avenue

Crownhill, Milton Keynes, Bucks, MK8 0AB

Tel: + 44 1908 267 345

Fax: + 44 1908 267 345



***SCHWINN® FITNESS***

Printed in Taiwan

Nautilus®

Bowflex®

Schwinn® Fitness

StairMaster®

Universal®